



Wilo-Stratos GIGA

- en** Installation and operating instructions
- fr** Notice de montage et de mise en service
- es** Instrucciones de instalación y funcionamiento

Fig. 1: IF-Modul

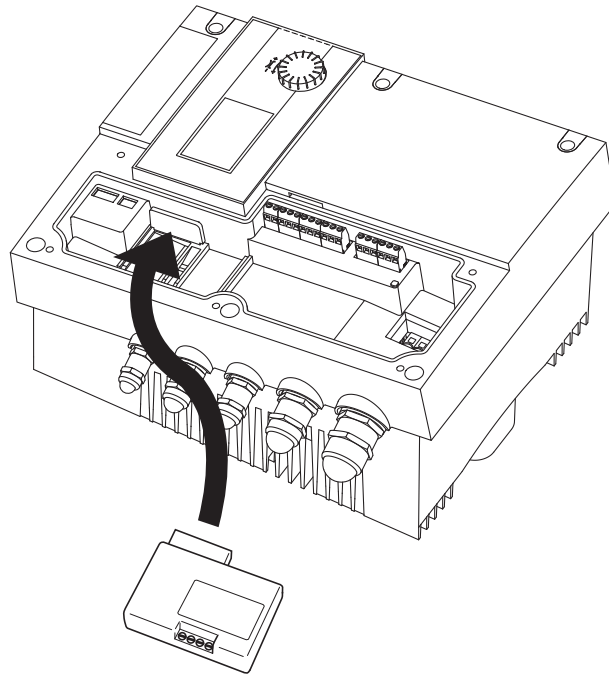

Fig. 2:

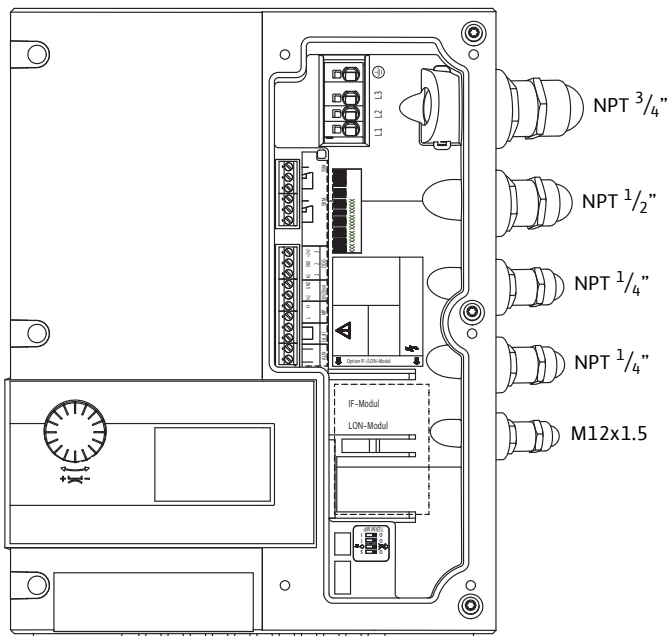

Fig. 3:

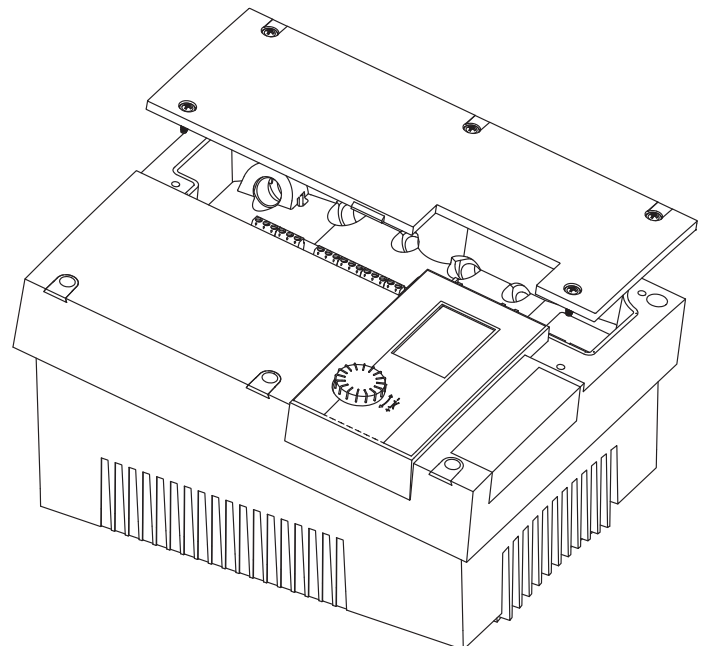

Fig. 4:

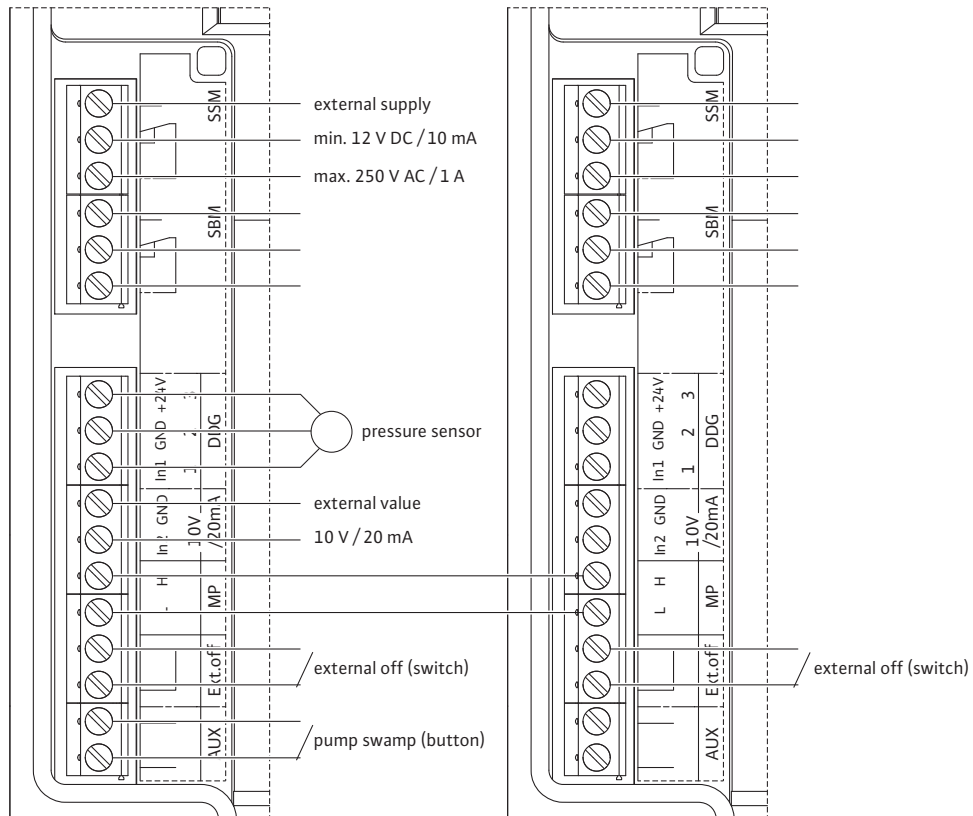
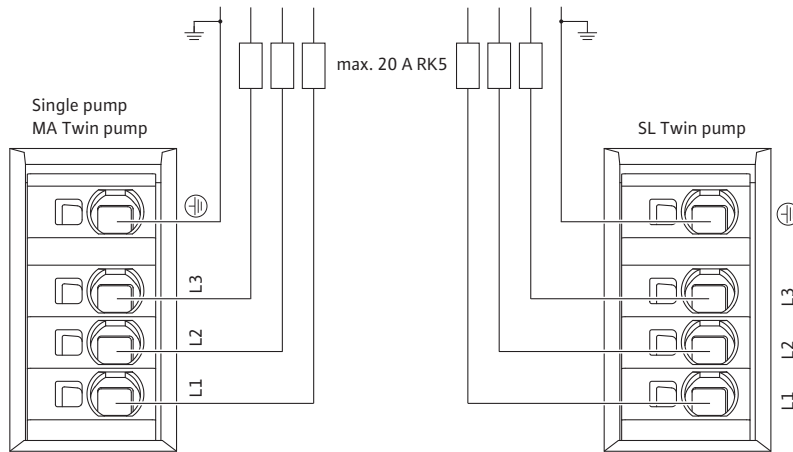

Fig. 5:

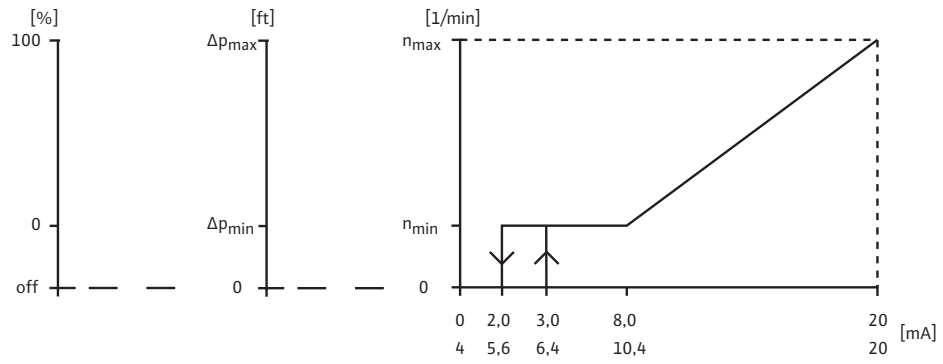
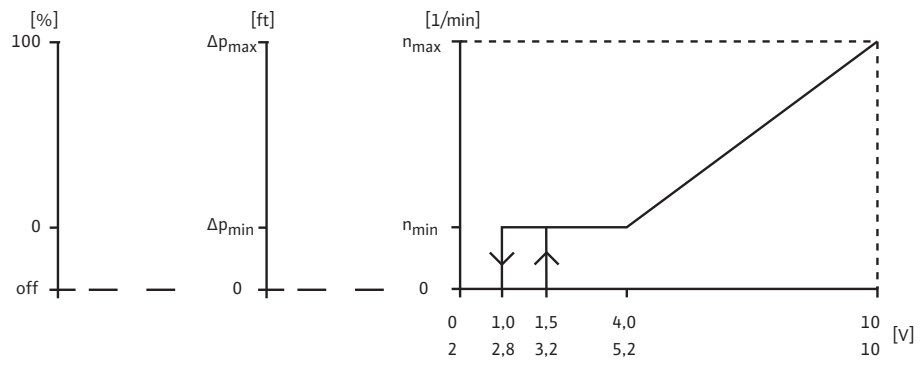

Fig. 6:

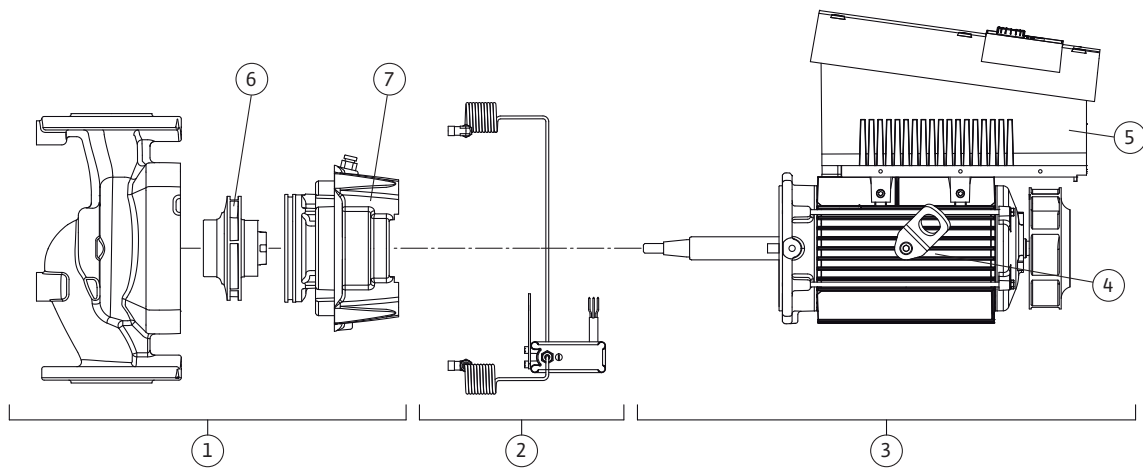
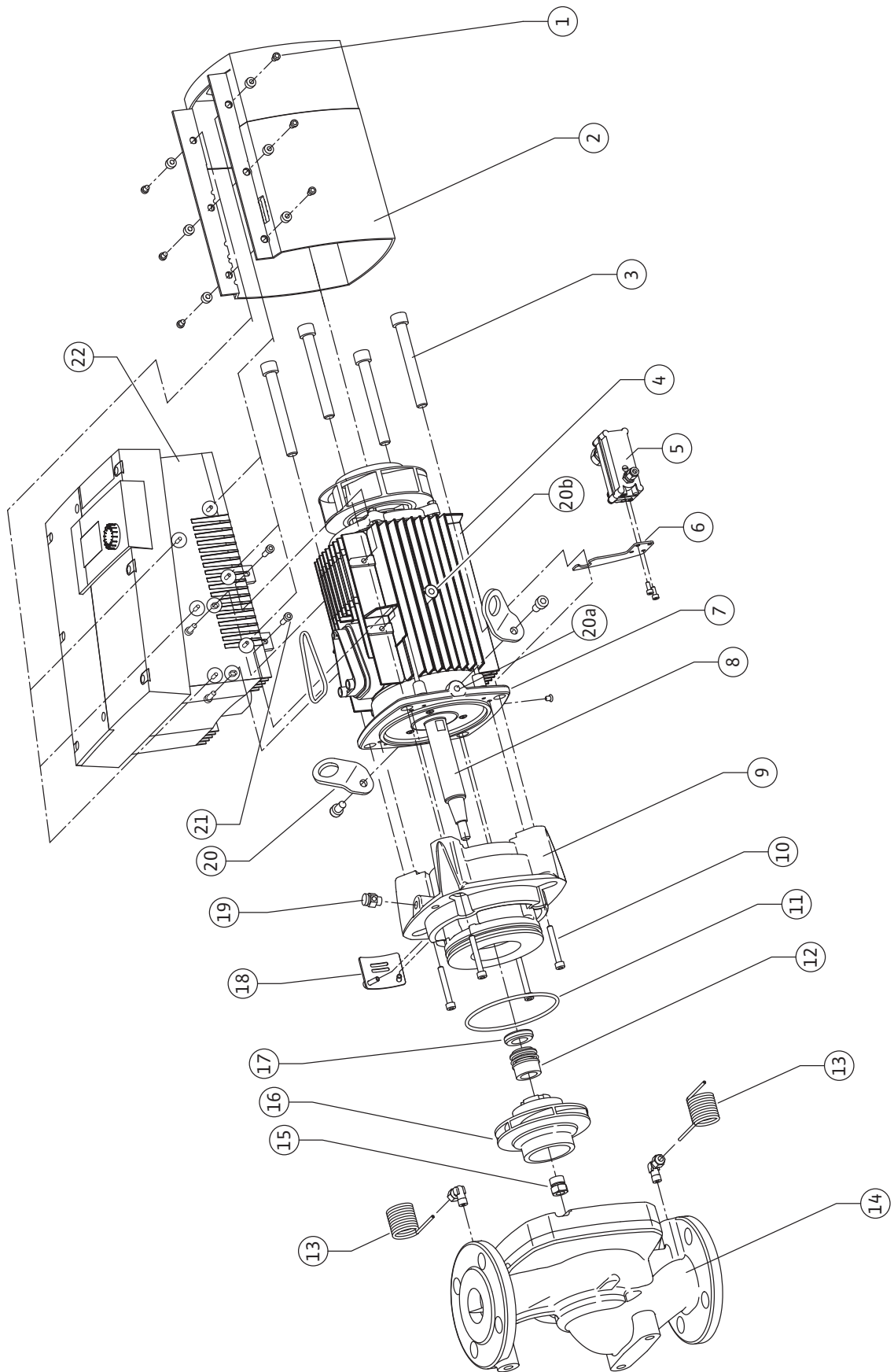

Fig. 7: Stratos GIGA



en	Installation and operating instructions	2
fr	Notice de montage et de mise en service	66
es	Instrucciones de instalación y funcionamiento	134

1	General notes	3
2	Safety	3
2.1	Symbols and signal words used in these operating instructions	3
2.2	Qualified personnel	4
2.3	Risks incurred by failure to comply with the safety precautions	4
2.4	Safety consciousness on the job	4
2.5	Safety precautions for the operator	4
2.6	Safety precautions for installation and maintenance work	5
2.7	Unauthorized alteration and manufacture of spare parts	5
2.8	Improper use	5
3	Transport and interim storage	5
3.1	Shipping	5
3.2	Transport for installation/dismantling purposes	6
4	Intended use	7
5	Product information	8
5.1	Type key	8
5.2	Technical data	9
5.3	Scope of delivery	10
5.4	Accessories	10
6	Description and function	10
6.1	Description of the product	10
6.2	Control modes	13
6.3	Dual pump function/Y-pipe application	14
6.4	Other functions	18
7	Installation and electrical connection	19
7.1	Permitted installations position and change of the arrangement of components before the installation	21
7.2	Installation	23
7.3	Electrical connection	24
8	Operation	29
8.1	Operating elements	29
8.2	Display structure	30
8.3	Explanation of standard symbols	30
8.4	Symbols in graphics/instructions	31
8.5	Display modes	31
8.6	Operating instructions	34
8.7	Menu elements reference	37
9	Commissioning	44
9.1	Filling and bleeding	44
9.2	Double pump installation/Y-pump installation	46
9.3	Setting the pump output	46
9.4	Setting the control mode	47
10	Maintenance	48
10.1	Air supply	50
10.2	Maintenance work	50
11	Faults, causes and remedies	57
11.1	Mechanical faults	57
11.2	Error table	58
11.3	Acknowledging errors	59
12	Spare parts	65
13	Disposal	65

1 General notes

About this document

These Installation and Operating Instructions form an integral part of the product. They must be kept close to the product and in readiness whenever required. Precise observance of these instructions is a precondition for use of the product for the intended purpose and for its correct operation.

These Installation and Operating Instructions conform to the relevant version of the equipment and the underlying safety standards valid at the time of going to press.

2 Safety

These instructions contain important information which must be followed when installing and operating the pump. It is therefore imperative that they be read by both the installer and the operator before the circulator is installed or started up.

Both the general safety instructions in the 'Safety precautions' section and those in subsequent sections indicated by danger symbols should be carefully observed.

2.1 Symbols and signal words used in these operating instructions

Symbols

Symbols:



General Safety symbol



Hazards from electrical causes



NOTE

Signal words

Signal words:

DANGER!

**Imminently hazardous situation.
Will result in death or serious injury if not avoided.**

WARNING!

The user can be exposed to (severe) injury. 'Warning' refers that harm to the user when the user is neglecting the procedure.

CAUTION!

The product is at risk of damage. 'Caution' refers to the product when the user is neglecting the procedures.

NOTE:

A notice with useful information for the user in relation to the product. It attends the user to possible problems.

Information applied directly to the product, such as:

- direction of rotation arrow,
- identifiers for connections,
- name plate,
- and warning sticker,

must be strictly complied with and kept in legible condition.

2.2 Qualified Personnel

The personnel installing the pump must have the appropriate qualifications for this work. Area of responsibility, terms of reference and monitoring of the personnel are to be ensured by the operator. If the personnel are not in possession of the necessary knowledge, they are to be trained and instructed. This can be accomplished if necessary by the manufacturer of the product at the request of the operator.

2.3 Risks incurred by failure to comply with the safety precautions

Non-observance of the safety instructions can result in risk of injury to persons and damage to the environment and the product/unit. Non-observance of the safety instructions results in the loss of any claims to damages.

In detail, non-observance can, for example, result in the following risks:

- danger to persons from electrical, mechanical and bacteriological influences,
- damage to the environment due to leakage of hazardous materials,
- damage to property,
- failure of important product/unit functions, failure of required maintenance and repair procedures.

2.4 Safety consciousness on the job

The safety instructions included in these installation and operating instructions, the existing national regulations for accident prevention together with any internal working, operating and safety regulations of the operator are to be complied with.

2.5 Safety precautions for the operator

- This appliance is not intended for use by persons (including children) with reduced physical, sensory or mental capabilities, or lack of experience and knowledge, unless they have been given supervision or instruction concerning use of the appliance by a person responsible for their safety.
- If hot or cold components on the product/the unit lead to hazards, local measures must be taken to guard them against touching.
- Leakage (e.i. from a shaft seal) of hazardous (e.i. explosive, toxic or hot) fluids must be discharged so that no danger to persons or to the environment arises.
- National statutory provisions are to be complied with.
- Highly flammable materials are always to be kept at a safe distance from the product.
- Danger from electrical current must be eliminated. National Electrical Codes, local codes and regulations must be followed.

2.6 Safety precautions for inspection and installation

The operator must ensure that all inspection and installation work is carried out by authorized and qualified specialists who have carefully reviewed these instructions.

Work on the pump/unit must be carried out only with the pump disconnected (locked out) from the electrical supply and at complete standstill. It is mandatory that the procedure described in the installation and operating instructions for shutting down the product/unit be complied with.

Immediately on conclusion of the work, all safety and protective devices must be put back in position and/or recommissioned.

2.7 Unauthorized alterations and manufacture of spare parts

Unauthorized modification and manufacture of spare parts will impair the safety of the product/personnel and will make void the manufacturer's declarations regarding safety.

Alterations to the product may only be carried out with the manufacturer's consent. The use of original spare parts and accessories authorized by the manufacturer will ensure safety. The use of any other parts may invalidate claims involving the liability of the manufacturer for any consequences.

2.8 Improper use

The operational safety of the supplied product can only be guaranteed if it is used in accordance with paragraph 4 of the operating instructions. The limits given in the catalogue or data sheet must under no circumstances be exceeded.

3 Transport and interim storage

3.1 Shipping

The pump is delivered from the factory packaged in a cardboard box or secured to a pallet and protected against dust and moisture.

Transport inspection

When receiving the material, check that there has been no damage during the transport. If shipping damage has occurred, take all necessary steps with the carrier within the allowed time.

Storage

Before installation, the pump must be kept dry, frost-free and protected from mechanical damage.



CAUTION! Risk of damage due to incorrect packaging!

If the pump is transported again at a later time, it must be packaged so that it cannot be damaged during transport.

- **Use the original packaging for this, or choose equivalent packaging. Use the provided transport eyes for lifting.**
- **Check the transport eyes before use for damage and secure fixation.**

3.2 Transport for installation/ dismantling purposes



WARNING! Risk of injuries to personnel!

Incorrect transport can cause injury to personnel.

- The pump must be transported using approved load-bearing equipment (e.g. block and tackle, crane, etc.). These are to be attached to the transport eyes at the motor flange (Fig. 8, shown here: lifting direction with vertical motor shaft).
- If necessary, e.g. in case of repairs, the transport eyes can be moved from the motor flange to the motor housing (see e.g. Fig. 9). Before installing the transport eyes at the motor housing, unscrew the spacers from the openings for the transport eyes (Fig. 7, Item 20b) (see chapter 10.2.1 "Replacing the mechanical seal" on page 50).
- Before using the transport eyes, check the eyes for damage and ensure that the fastening screws are completely screwed in and tightened.
- If the transport eyes have been moved from the motor flange and installed at the motor housing, then they are only approved for carrying or transporting the motor impeller unit (Fig. 9) and not for transport of the whole pump and not for separation of the motor impeller unit from the pump housing.
- If the transport eyes are moved from the motor flange to the motor housing, e.g. in case of repairs (see chapter 10 "Maintenance" on page 48), then these are to be reattached to the motor flange after completion of the installation or maintenance work and the spacers are to be screwed into the openings of the transport eyes (Fig. 7, Item 20a).

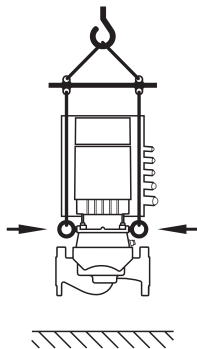

Fig. 8: Transporting the pump

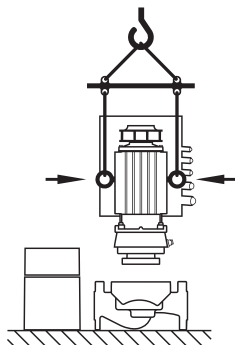

Fig. 9: Transport of the motor impeller unit

**NOTE:**

Swivel/turn the transport eyes to improve the balance in accordance with the direction of lifting. To do this, loosen and then retighten the fastening screws.

**WARNING! Danger of personal injury!**

Setting up the pump without securing it can lead to personal injury.

- Do not place the pump unsecured on the pump base. The base with the threaded holes is only used for attachment. When standing freely, the pump might not be sufficiently stable.

**DANGER! Danger of death!**

The pump itself and the parts of pump can be extremely heavy. Falling parts pose a risk of cuts, crush injuries, bruises or impacts, which may lead to death.

- Always use suitable lifting equipment and secure parts against falling.
- Never stand underneath a suspended load.
- Make sure the pump is securely positioned and is stable during storage and transport as well as prior to all installation and other assembly work.

4 Intended use**Purpose**

The glanded pumps of the Stratos GIGA series are intended for use as circulation pumps in building services.

Fields of application

They may be used for:

- Hot water heating systems
- Cooling and cold water circulation systems
- Industrial circulation systems
- Heat carrier circuits

Restrictions

The pumps are exclusively intended for installation and operation in enclosed rooms. Typical installation locations are technical rooms within the building with other domestic installations. The following is not permitted:

- Outdoor installation and operation outdoors

**DANGER! Danger of death!**

The permanently magnetized rotor inside the motor presents an acute danger to persons with pacemakers. Non-observance results in death or very serious injuries.

- Do not open the motor!
- Only allow Wilo customer service to dismantle and install the rotor for maintenance and repair work.



WARNING! Danger of personal injury!

Opening the motor leads to high, suddenly occurring magnetic forces. These can cause serious cuts, crushing injuries and bruises.

- Do not open the motor!
- Only allow Wilo customer service to dismantle and install the motor flange and the end shield for maintenance and repair work.



CAUTION! Danger of property damage!

Unpermitted substances in the fluid can destroy the pump. Abrasive solids (e.g. sand) increase pump wear.

Pumps without an Ex certificate are not suitable for use in potentially explosive areas.

- Intended use of the pump/installation also includes following these instructions.
- Any use above and beyond these is regarded as incorrect use.

5 Product information

5.1 Type key

The type key consists of the following elements:

Example:	Stratos GIGA 1.5/3-165
Stratos	High-efficiency pump
GIGA	Inline single pump
1.5	Pipe connection [inch] [flanges acc. ASME Class 125]
3-165	Infinitely variable nominal pump head 3 to 165 [ft]

5.2 Technical data

Property	Value	Remarks
Speed range	500 – 5130 rpm	Depends on pump type
Nominal diameter of pipe connection	1.5/2/2.5 in	
Pipe connections	Flanges acc. ASME Class 125	
Max. permissible liquid temperature range	Water only: from 32°F to 200°F [0°C to +90°C] Water/glycol up to 50 %: from -4°F to 250°F [-20°C to +120°C]	
Max. permissible liquid temperature range with high temperature seal	At 175 psi [12 bar]: from -4°F to 250°F [-20°C to +120°C] At 165 psi [11 bar]: from -4°F to 285°F [-20°C to +140°C]	
Ambient temperature min./max.	32°F to 104°F (0°C to +40°C)	
Max. admissible operating pressure	232 psi (16 bar)	
Insulation class	F	
Protection class	Enclosure Type 5 Indoor Use Only IP55	Only for US market
Electromagnetic compatibility Emitted interference in acc. with Interference resistance in acc. with	EN 61800-3 EN 61800-3	Residential Industrial
Sound pressure level ¹⁾	< 74 dB(A)	Depends on pump type
Approved fluids	Heating water Cooling/cold water Water/glycol mixture up to 40% vol. Other fluids	Standard version Standard version Standard version Only for special version
Electrical connection	3~380 V AC to 480 V AC ±10%, 50/60 Hz	Supported network types: Delta, wye networks
Internal electric circuit	PELV, galvanically isolated	Isolated Secondary Circuit, Limited voltage/current circuit
Speed control	Built-in frequency converter	
Relative humidity		
- at T _{environment} = 86°F (30°C)	90%, non-condensing	
- at T _{environment} = 104°F (40°C)	60%, non-condensing	

¹⁾ Average value of the sound-pressure level at a spatially rectangular measuring surface at a distance of 3.3 ft (1 m) from the pump surface in accordance with ISO 3744

Please state all the information on the pump name plate when ordering spare parts.

Fluids

If water/glycol mixtures are used (or fluids with a viscosity other than that of pure water), an increase in power consumption of the pump is to be taken into account. Only use mixtures with corrosion inhibitors. The respective manufacturer's instructions are to be observed.

- The fluid must be free of sediments.
- Wilo's approval must be obtained for use of other media.
- Mixtures with a proportion of glycol of > 10% influence the $\Delta p-v$ pump curve and the flow calculation.

**NOTE:**

The flow value shown on the IR-Monitor display or output to the building management system must not be used to control the pump. This value is merely an indicator of general trends.

A flow value is not an output on every type of pump.

**NOTE:**

Always read and follow the material safety data sheet for the fluid being pumped!

5.3 Scope of delivery

- Stratos GIGA pump
- Installation and operating instructions

5.4 Accessories

Accessories must be ordered separately:

- Three mounting brackets with fixation elements for installation on a base
- Installation aid for mechanical seal
- IR-Monitor
- IF-Module PLR for connecting to PLR/interface converter
- IF-Module LON for connection to the LONWORKS network
- BACnet IF-Module
- Modbus IF-Module
- CAN IF-Module

See catalogue for detailed list.

**NOTE:**

IF-Module may only be plugged in when the pump is deenergized (voltage-free).

6 Description and function**6.1 Description of the product**

The Wilo-Stratos GIGA high-efficiency pumps are glanded pumps with built-in power adjustment and “Electronic Commutated Motor” (ECM) technology. The pumps are designed as single-stage low-pressure centrifugal pumps with flange connection and mechanical seal.

The pumps can be installed both directly as pipe installation pumps in sufficiently secured pipes or be placed on a foundation base.

The pump housing is designed as an in-line construction; i.e. the suction and pressure-side flanges are on one axis. All pump housings are provided with a pump base. Installation on a foundation base is recommended.

Main components

Fig. 7 shows an exploded drawing of the pump with the main components. In the following, the assembly of the pump is explained in detail.

Arrangement of the main components in accordance with Fig. 7 and Tab. 1:

No.	Part
1	Fastening screws of the fan cover
2	Fan cover
3	Motor impeller unit fastening screws
4	Motor housing
5	Differential pressure sensor (DDG)
6	DDG holder
7	Motor flange
8	Motor shaft
9	Lantern
10	Fastening screws of the lantern
11	O-ring
12	Rotating unit of the mechanical seal (mechanical seal)
13	Pressure measuring line
14	Pump housing
15	Impeller nut
16	Impeller
17	Counter ring of the mechanical seal
18	Protective plate
19	Bleed valve
20	Transport eye
20a	Attachment points for transport eyes at the motor flange
20b	Attachment points for transport eyes at the motor housing
21	Fastening screws of the electronic module
22	Electronic module

Tab. 1: Arrangement of the main components

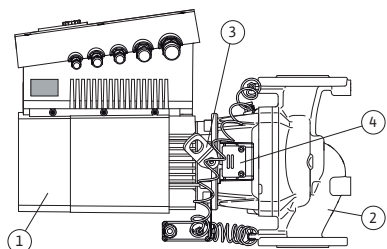

Fig. 10: Pump assembly

The typical characteristic of the Stratos GIGA series is the jacket cooling of the motor. The air current is optimally conducted by the long fan cover (Fig. 10, Item 1) for cooling the motor and the electronic module.

(Fig. 10, Item 2) shows the pump housing with a special lantern channel to reduce the load of the impeller.

The transport eyes (Fig. 10, Item 3) are to be used in accordance with chapters 3 and 10.

The window in the lantern that is covered with the protective plate (Fig. 10, Item 4) is used for maintenance work in accordance with chapter 10 "Maintenance" on page 48. The window can also be used to check for leaks with consideration of the safety regulations in accordance with chapter 9 "Commissioning" on page 44 and chapter 10 "Maintenance" on page 48.

Name plates

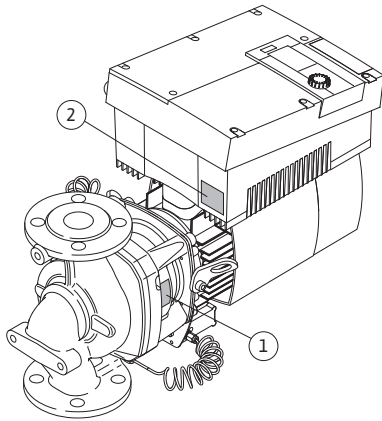

Fig. 11: Arrangement of the name plates:
Pump name plate, electronic module name plate

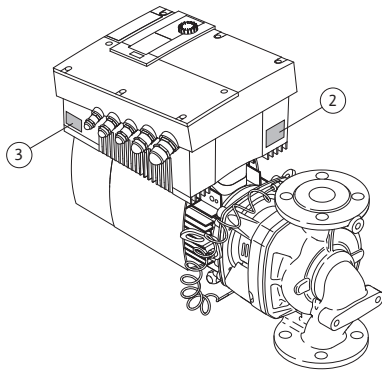

Fig. 12: Arrangement of the name plates:
Drive name plate, electronic module name plate

Functional assemblies

The Wilo-Stratos GIGA has three name plates:

- The pump name plate (Fig. 11, Item 1) includes the serial number (Ser.-No.../...), which is, for example, required for spare parts ordering.
- The electronic module name plate (electronic module = inverter or frequency converter) (Fig. 11, Item 2) indicates the designation electronic module being used.

- The drive name plate is at the inverter on the side with the cable lead-throughs (Fig. 12, Item 3). The electrical connection is to be made in accordance with the specifications on the drive name plate.

The pump has the following main functional assemblies:

- Hydraulic unit (Fig. 6, Item 1), consisting of the pump housing, impeller (Fig. 6, Item 6) and lantern (Fig. 6, Item 7)
- Optional differential pressure sensor (Fig. 6, Item 2) with connecting and fastening parts
- Drive (Fig. 6, Item 3), consisting of EC motor (Fig. 6, Item 4) and electronic module (Fig. 6, Item 5).

The hydraulic unit is not a "ready-to-assemble" assembly due to the motor shaft which goes through; it is taken apart for most maintenance and repair work.

The hydraulic unit is driven by the EC motor (Fig. 6, Item 4), which is controlled from the electronic module (Fig. 6, Item 5).

As far as the assembly is concerned, the impeller (Fig. 6, Item 6) and the lantern (Fig. 6, Item 7) depend on the motor impeller unit (Fig. 13).

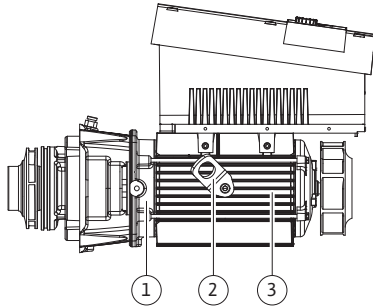

Fig. 13: Motor impeller unit

Electronic module

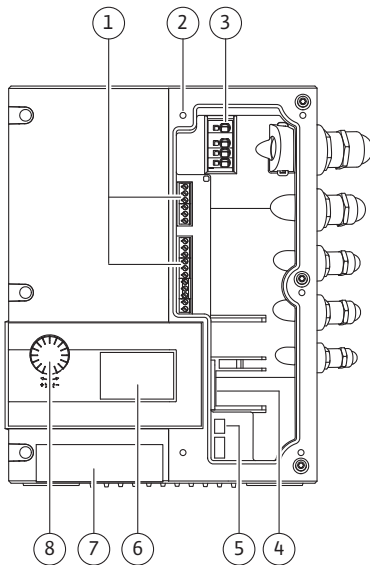
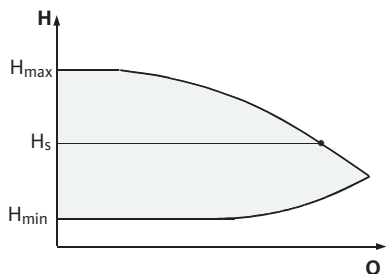

Fig. 14: Electronic module

6.2 Control modes

Fig. 15: Δp -c control

For the following purposes, the motor impeller unit can be separated from the pump housing (which can remain in the piping) (also see chapter 10 “Maintenance” on page 48):

- To provide access to the inside parts (impeller and mechanical seal)
- To make it possible to separate the motor from the hydraulic unit.

When this is done, the transport eyes (Fig. 13, Item 2) are removed from the motor flange (Fig. 13, Item 1), taken to the motor housing and refastened there with the same screws to the motor housing (Fig. 13, Item 3).

The electronic module controls the speed of the pump to a setpoint that can be adjusted within the control range.

The hydraulic output is controlled by differential pressure and the set control mode. In all control modes, however, the pump adapts itself continuously to the changing power requirements of the system, which is the case especially when thermostatic valves or mixers are used.

The basic advantages of the electronic control are:

- Energy saving at the same time as reduced operating costs
- Fewer differential pressure valves required
- Reduction of flow noise
- Adaptation of the pump to changing operating requirements

Legend (Fig. 14):

- 1 Control terminals
- 2 Attachment points cover
- 3 Power terminals (mains terminals)
- 4 Interface for IF-Module
- 5 DIP switch
- 6 Display
- 7 Infrared window
- 8 The red button

The selectable control modes are:

Δp -c:

The electronics keep the differential pressure created by the pump above the permitted feed flow range constantly at the pre-selected differential pressure setpoint H_s up to the maximum pump curve (Fig. 15).

Q = Volume flow

H = Differential pressure (min./max.)

H_s = Differential pressure setpoint



NOTE:

For further information about setting the control mode and the associated parameters, see chapter 8 “Operation” on page 29 and chapter 9.4 “Setting the control mode” on page 47.

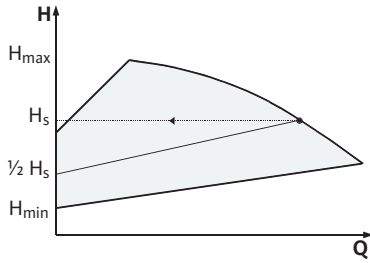

Fig. 16: Δp -v control

Δp -v:

The electronics linearly change the differential pressure setpoint to be kept by the pump between the delivery heads H_s and $\frac{1}{2} H_s$. The differential pressure setpoint H_s decreases or increases with the volume flow (Fig. 16).

Q = Volume flow

H = Differential pressure (min./max.)

H_s = Differential pressure setpoint



NOTE:

For further information about setting the control mode and the associated parameters, see chapter 8 "Operation" on page 29 and chapter 9.4 "Setting the control mode" on page 47.



NOTE:

A differential pressure sensor is needed for the control modes that are being performed (Δp -c and Δp -v) which sends the actual value to the electronics.

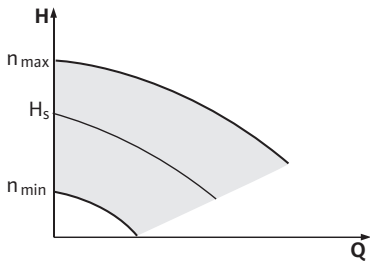

Fig. 17: Manual control mode

Manual control mode:

The speed of the pump can be kept to a constant speed between n_{\min} and n_{\max} (Fig. 17). "Manual control" mode deactivates all other control modes.

PID control:

If the aforementioned standard control modes cannot be used – e.g. if other sensors are to be used or the distance to the pump is very long – then the PID control (**P**roportional-**I**ntegral-**D**ifferential control) is available.

By selecting a good combination of individual control portions, the operator can ensure fast reacting, constant control without lasting setpoint deviations.

The output signal of the selected sensor can take any intermediate value. The respective actual value reached (sensor signal) will be shown as a percentage (100% = maximum measurement range of the sensor) on the status page of the menu.



NOTE:

The displayed percentage value only corresponds indirectly to the current delivery head of the pump(s). It can be, for example, that the maximum delivery head has already been reached at a sensor signal < 100%. For further information about setting the control mode and the associated parameters, see chapter 8 "Operation" on page 29 and chapter 9.4 "Setting the control mode" on page 47.



NOTE:

The properties described below are only available if the internal MP interface (MP = Multi Pump) is used.

6.3 Dual pump function/Y-pipe application

- Both pumps are controlled by the master pump.

If one of the pumps malfunctions, the other will run according to the master's control settings. In case of a total failure of the master, the slave pump operates at emergency operation speed.

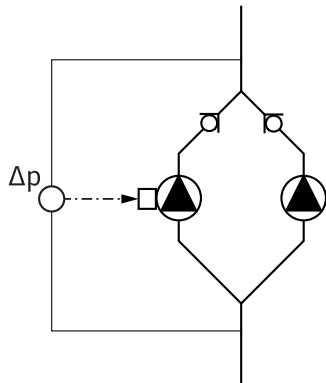

Fig. 18: Example, DDG connection

InterFace module (IF-Module)

The emergency operation speed can be set in menu <5.6.2.0> (see chapter 6.3.3 on page 17).

- The master's display will show the status of the double pump. On the slave display, 'SL' will appear.
- The master pump is the left pump in the direction of flow.
Connect the differential pressure sensor to this pump.

The measuring points of the differential pressure sensor of the master pump must be on the suction and pressure side of the double-pump system in the corresponding collector pipe (Fig. 18).

For communication between pumps and the building management system, one IF-Module (accessories) is required per pump. This is plugged into the terminal space (Fig. 1).

- The master-slave communication uses an internal interface (terminal: MP, Fig. 26).
- Normally for double pumps, only the master pump must be equipped with an IF-Module.

Communication	Master pump	Slave pump
PLR/Interface converter	IF-Module PLR	No IF-Module necessary
LONWORKS network	IF-Module LON	No IF-Module necessary
BACnet	BACnet IF-Module	No IF-Module necessary
Modbus	Modbus IF-Module	No IF-Module necessary
CAN bus	CAN IF-Module	No IF-Module necessary



NOTE:

The procedure and further information for commissioning and configuring the IF-Module on the pump can be found in the installation and operating instructions of the IF-Module used.

6.3.1 Operating modes

Main/standby operation

Each of the two pumps provides the configuration flow rate. The other pump is available in case of malfunction or runs after pump cycling. Only one pump runs at a time (see Fig. 15, 16 and 17).

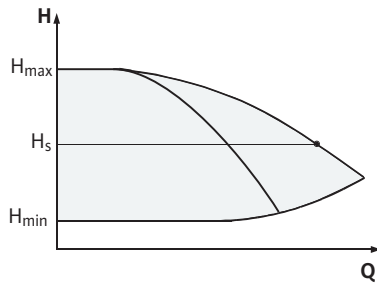
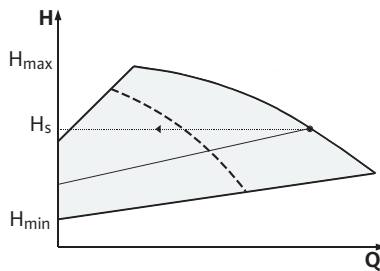
Parallel operationFig. 19: Δp -c control (parallel operation)Fig. 20: Δp -v control (parallel operation)

In the partial load range, the hydraulic output is provided at the beginning by one pump. The second pump will be switched on when it is most effective to do this, i.e. when the total power consumption P_1 of both pumps in the partial load range is less than the power consumption P_1 of one pump. Both pumps will then be simultaneously adjusted upwards to the maximum speed (Fig. 19 and 20).

In manual control mode, both pumps always run synchronously. Parallel operation of two pumps is only possible with two identical pump types.

Compare to chapter 6.4 "Other functions" on page 18.

6.3.2 Behavior in dual pump operation**Pump cycling**

In dual pump operation, a pump cycling occurs periodically (the period can be set; Factory setting: 24 h).

Pump cycling can be triggered:

- Internally, time-controlled (menu <5.1.3.2> + <5.1.3.3>)
- Externally (menu <5.1.3.2>) by a positive edge at the "AUX" contact (see Fig. 26),
- Or manually, (menu <5.1.3.1>)

Manual or external pump cycling is possible five seconds after the last pump cycling, at the earliest.

Activation of external pump cycling simultaneously deactivates internal time-controlled pump cycling.

Behavior of the inputs and outputs

Actual value input In1, setpoint input In2

- Set at the master: acts on the whole unit

"Ext off":

- Set at the master (menu <5.1.7.0 >): depending on the setting in menu <5.1.7.0 >, acts only on the master or on the master and the slave.
- Set at the slave: acts only on the slave.

Fault and run signals**ESM/SSM:**

- A collective fault signal (SSM) can be connected to the master for a central control center.
- In this case, the contact may only be made to the master.
- The display is for the whole unit.
- This signal can be programmed on the master (or using the IR-Monitor) as an individual fault signal (ESM) or a collective fault signal (SSM) in menu <5.1.5.0>.
- The contact must be made to each pump for individual fault signals.

EBM/SBM:

- A collective run signal (SBM) can be connected to the master for a central control center.
- In this case, the contact may only be made to the master.
- The display is for the whole unit.
- This signal can be programmed on the IR-Monitor as an individual run signal (EBM) or collective run signal (SBM) (menu <5.1.6.0>).
- The functions – “Readiness”, “Operation”, “Mains on” – from EBM/SBM can be set at <5.7.6.0> at the master.

**NOTE:**

- “Readiness” means: The pump can run; there is no fault.
- “Operation” means: Motor shaft turns.
- “Mains on” means: Mains voltage is present.

- The contact must be made to each pump for individual run signals.

No further settings can be made on the slave beyond “Ext off” and “Block/release pump”.

Operating possibilities at the slave pump**6.3.3 Operation during interruption of communication**

When communication is interrupted between two pump heads in dual pump operation, both displays show the error code 'E052'. Both pumps behave as single pumps for as long as the interruption lasts.

- Both modules report the fault via the ESM/SSM contact.
- The slave pump runs in emergency operation (manual control) mode according to the emergency operation speed previously set on the master (see menu items <5.6.2.0>). The factory setting of the emergency operation speed is about half of the maximum speed of the motor.
- After acknowledging the fault display, the status indicator will be shown on both pump displays for the duration of the communication interruption. This resets the ESM/SSM contact at the same time.
- The slave pump display will show the symbol  – Pump running in emergency operation).
- The (former) master pump continues to have control. The (former) slave pump follows the emergency operation settings. It is only possible to exit emergency operation by actuating the factory setting or, after ending the communication interruption, by shutting power off and on again.

**NOTE:**

- During communication interruptions, the (former) slave pump cannot run in auto control, since the differential pressure sensor has switched to the master. When the slave pump is running in emergency operation mode, changes cannot be made to the module.
- After the end of the communication interruption, the pumps will resume regular dual pump operation as before the fault.

Slave pump behavior**Leaving emergency operation at the slave pump:**

- Factory settings restored
During a communication interruption on the (former) slave, if emergency operation is discontinued because the factory settings have been restored, the (former) slave will start up with the factory settings of a single pump. It will then run in Δp -c mode at approximately half the maximum delivery head.

**NOTE:**

In the absence of a sensor signal, the (former) slave will run at maximum speed. To prevent this, the (former) master's differential pressure sensor signal can be looped through. When the double pump is operating normally, it is not affected by sensor signals pending on the slave.

- **Mains off, Mains on**

During a communication interruption on the (former) slave, if emergency operation is discontinued due to mains off, mains on, the (former) slave will start up with the latest emergency operation settings received from the master (for example, control mode with preset speed or off).

Master pump behavior

Leaving emergency operation at the master pump:

- **Factory settings restored**

During a communication interruption on the (former) master, if the factory settings are restored, it will start up with the factory settings of a single pump. It will then run in Δp -c mode at about half the maximum delivery head.

- **Mains off, Mains on**

During a communication interruption on the (former) master, if emergency operation is discontinued due to power cycling (mains off, mains on), the (former) master will start up with the latest settings it has from the double pump configuration.

6.4 Other functions

Disabling or enabling a pump

A particular pump can generally be enabled or disabled in terms of operation in menu <5.1.4.0>. A disabled pump cannot be used in operation until the disabling has been manually lifted.

The setting can be made at each pump directly or over the infrared interface.

Pump exercise

A pump exercise will be carried out after the end of a period of 24 h and 2 minutes after the pump or a pump head has been in standstill. The reason for the standstill does not matter (Manual off, Ext. off, Fault, Adjustment, Emergency operation, BMS setting). This procedure is repeated until the pump is switched back on via a control mechanism. The "pump exercise" function cannot be disabled via the menu or any other interfaces. As soon as the pump is switched on via the control system, the countdown to the next pump exercise is interrupted.

The duration of a pump exercise is 5 seconds. The motor turns at minimum speed during this period. If both pump heads of a double pump are switched off, i.e. by Ext. off, then both run for the period of 5 seconds. The pump exercise also takes place in "Main/standby operation" operating mode if the pump cycling takes more than 24 h. A pump exercise is also attempted even in case of a fault.

The remaining operating time until the next pump exercise can be seen in menu <4.2.4.0>. This menu is only available when the motor is stopped. The number of pump exercises can be seen in menu <4.2.6.0>.

All faults, with the exception of warnings, that occur during the pump exercise switch the motor off. The corresponding fault code is shown on the display.

Behavior after being switched on

The pump operates with its factory settings in initial commissioning.

- The service menu deals with the setting and converting of individual pumps; see chapter 8 “Operation” on page 29.
- To correct faults, also see chapter 11 “Faults, causes and remedies” on page 57.

**CAUTION! Danger of personal damage!**

Modifying the settings for the differential pressure sensor can lead to malfunctions. The factory settings are configured for the supplied WILO differential pressure sensor.

- **Default value: input In = 0-10 volts, pressure value correction = ON**
- **When using the supplied Wilo differential pressure sensor, these settings must not be changed! Modifications are only needed if another differential pressure sensor is used.**

Switching frequency

At high ambient temperatures (> 104°F/40°C), the thermal load on the module can be reduced by lowering the switching frequency (menu <4.1.2.0>).

**NOTE:**

Switchover/modification must only be carried out when pump is at standstill (motor not running).

The switching frequency can be changed via the menu or the CAN bus. Lower switching frequencies result in increased noise levels.

Variants

If the menu <5.7.2.0> “Pressure value correction” is not available on the display of a given pump, that pump is a variant in which the following functions are not available:

- Pressure value correction (menu <5.7.2.0>)
- Efficiency-optimized activation and deactivation in double pumps
- Flow rate trend display

7 Installation and electrical connection**Safety****DANGER! Danger of death!**

Incorrect installation and incorrect electrical connection can pose a risk of fatal injury.

- **Have the electrical connections established by licensed electricians only, in compliance with the applicable regulations.**
- **Accident prevention regulations must be observed!**

**DANGER! Danger of death!**

Failure to install safety devices of the electronic module and the motor can cause electrical shock or contact with rotating parts, potentially resulting in life-threatening injuries.

- Before commissioning, all safety devices such as module covers or fan covers that were removed must be reinstalled.

**DANGER! Danger of death!**

Deadly danger due to module not being installed! Fatal voltages can be present at the motor contacts.

- Normal operation of the pump is only permitted with the module installed.
- The pump is not allowed to be connected or operated without the module being installed.

**DANGER! Danger of death!**

The pump itself and the parts of pump can be extremely heavy. Falling parts pose a risk of cuts, crush injuries, bruises or impacts, which may lead to death.

- Always use suitable lifting equipment and secure parts against falling.
- Never stand underneath a suspended load.
- Make sure the pump is securely positioned and is stable during storage and transport as well as prior to all installation and other assembly work.

**CAUTION! Danger of property damage!**

Danger of damage due to incorrect handling.

- Have the pump installed by qualified personnel only.
- The pump may never be operated without the module being installed.

**CAUTION! Damage to the pump due to overheating!**

The pump must not be allowed to operate dry for more than 1 minute. Dry running causes a build-up of energy in the pump, which can damage the shaft, impeller, and mechanical seal.

- Have the pump installed by qualified personnel only.
- Make sure that the volume flow does not go below the minimum value Q_{min} .
- Calculation of Q_{min} :

$$Q_{min} = 10\% \times Q_{max \text{ pump}} \times \frac{\text{Actual speed}}{\text{Max. speed}}$$

7.1 Permitted installation positions and change of the arrangement of components before the installation

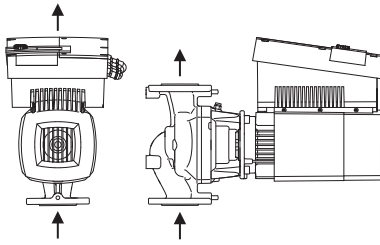

Fig. 21: Arrangement of the components upon delivery

Permitted installation positions with horizontal motor shaft

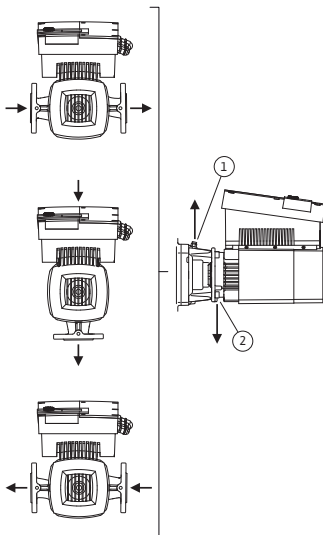

Fig. 22: Permitted installation positions with horizontal motor shaft

Permitted installation positions with vertical motor shaft

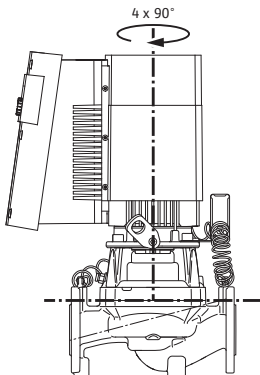

Fig. 23: Permitted installation positions with vertical motor shaft

The component arrangement concerning the pump housing is pre-installed as a factory setting (see Fig. 21) and can be changed if need be at the operating location. This can be necessary, for example, to:

- Ensure the bleeding of the pumps
- Make operation easier
- Prevent impermissible installation positions (i.e. motor and/or electronic module downwards)

In most cases, it is enough to rotate the motor impeller unit relative to the pump housing. The possible arrangement of components is the result of the permitted installation positions.

The permitted installation positions with horizontal motor shaft are shown in Fig. 22. Any installation position is allowed except for “electronic module facing down”. The venting of the pump is only ensured when the bleed valve is pointing upwards (Fig. 22, Item 1).

Only in this position can condensate be directed away and into a provided drilled hole (Fig. 22, Item 2).

The permitted installation positions with vertical motor shaft are shown in Fig. 23. Any installation position is allowed except for “motor facing down”.

The motor impeller unit can – relative to the pump housing – be arranged in four different positions (each shifted by 90°).

Changing the component arrangement



NOTE:

To make the installation work easier, the “dry” installation of the pump in the piping can be helpful, e.g., installation without electrical connection and without filling of the pump or system.

- Carry out steps 5 to 10 in accordance with chapter 10.2.1 “Replacing the mechanical seal” on page 50.
- Rotate the motor impeller unit by 90° or 180° in the desired direction and install the pump in the reverse order.
- Fasten the holder of the differential pressure sensor (Fig. 7, Item 6) with one of the screws (Fig. 7, Item 3) on the side opposite the electronic module (the position of the sensor relative to the module does not change when doing this).
- Wet the O-ring (Fig. 7, Item 11) well before installation (do not install the O-ring in a dry condition).



NOTE:

Be sure that the O-ring (Fig. 7, Item 11) is not installed in a twisted position or squeezed, pinched, or cut during installation.

- Before commissioning, fill the pump/system and apply system pressure; check for leaks afterwards. If there is a leak at the O-ring, first air will come out of the pump. This leakage can, for example, be checked with a leakage spray at the gap between the pump housing and the lantern as well as their screwed connections.
- In the event of continual leakage, use a new O-ring, if need be.



CAUTION! Danger of personal injury!

Incorrect handling can result in property damage.

- **If the transport eyes are moved from the motor flange to the motor housing, e.g. to replace the motor impeller unit, then these have to be reattached to the motor flange after completion of the installation work (also see chapter 3.2 “Transport for installation/dismantling purposes” on page 6). In addition, the spacers are also to be screwed back into the openings (Fig. 7, Item 20b).**



CAUTION! Danger of property damage!

Incorrect handling can result in property damage.

- **When turning the components, make sure that the pressure measuring lines are not bent or kinked.**
- When reinstalling the differential pressure sensor, bend the pressure measuring lines evenly and as little as possible to put them into the required position or into a suitable position. When doing this, do not deform the areas at the clamp boltings.
- For optimal positioning of the pressure measuring lines, the differential pressure sensor can be separated from the holder (Fig. 7, Item 6), rotated by 180° around the longitudinal axis and reinstalled.

7.2 Installation

Preparation

- The pump should only be installed following completion of all welding and soldering work and, if necessary flushing of the pipe system. Dirt can cause pump failure.
- The pumps must be protected from the weather and installed in a frost/dust-free, well-ventilated environment which is not potentially explosive. The pump must not be installed outdoors.
- Install the pump in a place that is easy to access so that subsequent inspections, maintenance (e.g. mechanical seal) or replacement is easily possible. Air flow to the electronic module's heat sink must not be restricted.

Positioning/alignment

- A hook or a lug with sufficient load-bearing capacity must be installed vertically over the pump (total weight of the pump: see catalogue/data sheet). This is to allow hoisting gear or similar aids to be attached to the pump during maintenance or repair work.



DANGER! Danger of death!

The pump itself and the parts of pump can be extremely heavy. Falling parts pose a risk of cuts, crush injuries, bruises or impacts, which may lead to death.

- Always use suitable lifting equipment and secure parts against falling.
- Never stand underneath a suspended load.



CAUTION! Danger of property damage!

Danger of damage due to incorrect handling.

- If the transport eyes have been moved from the motor flange and installed at the motor housing, then they are only approved for carrying or transporting the motor impeller unit (Fig. 24) and not for transport of the whole pump and not for separation of the motor impeller unit from the pump housing (pay attention to the previous dismantling and subsequent installation of the spacer).
- Transport eyes that have been installed at the motor housing are not approved for the transport of the whole pump and not for separating or pulling out of the motor impeller unit from the pump housing.
- Only lift the pump with approved load-bearing equipment (e.g. block and tackle, crane, etc.; see chapter 3 "Transport and interim storage" on page 5).

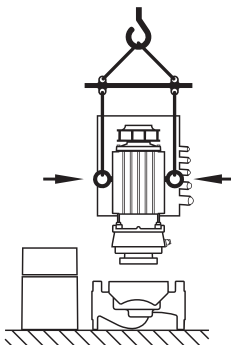

Fig. 24: Transport of the motor impeller unit

- When installing the pump, an axial minimum wall/roof clearance of the motor's fan cover of 16 in (400 mm) is to be maintained.



NOTE:

Shut-off devices shall be installed in front of and behind the pump in all cases, in order to avoid having to drain the entire system when checking or replacing the pump.



CAUTION! Danger of property damage!

A volume flow going against or with the direction of flow (turbine operation or generator operation) can cause irreparable damage to the drive.

- **A non-return valve shall be installed on the pressure side of each pump.**

- The pipes and pump must be free of mechanical stress when installed. The pipes must be fastened in such a way that the pump does not bear the weight of the pipes.
- The direction of flow must correspond to the direction arrow on the pump housing flange.
- The bleed valve at the lantern (Fig. 7, Item 19) must always be pointed upwards if the motor shaft is horizontal (Fig. 6/7). If the motor shaft is vertical, any orientation is permitted.
- Any installation position is allowed except for "motor facing down".
- The electronic module must not face downwards.



NOTE:

When pumping out a tank, ensure that the fluid level is always high enough above the suction port of the pump so that the pump never runs dry. The minimum inlet pressure must be maintained.

- When the pump is used in air-conditioning or cooling systems, the condensation that forms in the lantern can be drained specifically via an existing hole. A drain pipe can be connected at this opening. Small amounts of fluid leakage can be also drained off.



NOTE:

In the case of insulated systems, only the pump housing may be insulated, not the lantern or motor.

When isolating the pump, an isolation material without ammonia compounds must be used in order to prevent stress cracking corrosion at the union nuts. If that is impossible, a direct contact with the brass screws has to be prevented, e.g. with stainless-steel screw connections that are available as accessories. Another alternative is the use of a corrosion protection tape (e.g. isolation tape).

7.3 Electrical connection



NOTE:

The local requirements are to be taken into account.

Safety



DANGER! Danger of death!

A fatal shock may occur if the electrical connection is not made correctly.

- **Only allow the electrical connection to be made by an electrician approved by the local electricity supplier and in accordance with applicable local regulations.**
- **National Electrical Codes (NEC), local codes and regulations must be strictly followed.**
- **Observe the installation and operating instructions for the accessories!**

**DANGER! Danger of death!**

For generator operation or turbine operation of the pump (rotor drive), there may be a dangerous contact voltage at the module's contacts.

- Close the shut-off device in front of and behind the pump.

**DANGER! Danger of death!**

Contact voltage can be life-threatening.

Work on the module may only be started after waiting five minutes, due to the dangerous residual contact voltage (capacitors).

- Before working on the pump, disconnect the power supply and wait for five minutes.
- Check to ensure all connections (including potential-free contacts) are voltage-free.
- Open the module only to carry out the electrical connection of the pump at the corresponding terminals, as described in this chapter. Never open the module to have access to the internal components. No work must be done at the components which are located inside the module.
- Never use an object to poke around the openings on the module and never insert anything into the module!

**WARNING! Danger of mains overload!**

An inadequate mains design can lead to system failures and even to cable fires due to mains overload.

- When designing the mains, with regard to the cable cross-sections and fuses, give special consideration to the fact that short-term simultaneous operation of all pumps is possible in multi-pump operation.

**CAUTION! Possible damage of the pump!**

In insulation tests with a high-voltage generator the pump is to be disconnected on all poles from the mains in the control module. The free cable ends are to be insulated in accordance with the voltage of the highvoltage generator.

Installation notes

Integral solid state short circuit protection does not provide branch circuit protection. Branch circuit protection must be provided in accordance with the Manufacturer Instructions, National Electrical Code and any additional local codes.

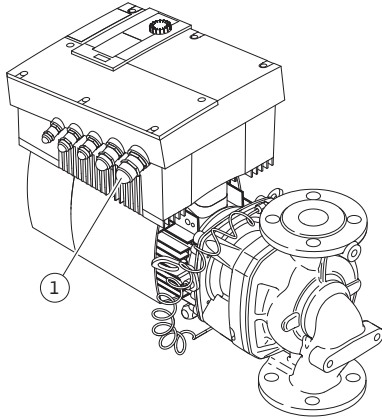

Fig. 25: NPT^{3/4} " threaded cable connection



- The electrical connection must be established via a fixed power cable which has a plug attachment or an all-pole switch with a contact opening width of at least $\frac{1}{8}$ " (3 mm). Use 140/167 °F (60/75 °C) copper conductors only. The power cable is to be fed through the NPT $\frac{3}{4}$ " threaded cable connection (Fig. 25, Item 1). Cross-section of power cable to be maintained:
min. AWG16 (4 x 1.5 mm²)
max. AWG12 (4 x 4.0 mm²)

NOTE:



For the right screw tightening torque of the terminals see "Tab. 2 Screw tightening torques" on page 55. Be sure to use a calibrated torque wrench.

- In order to comply with electromagnetic compatibility standards, the following cables must always be shielded:
 - DDG (if installed on-site)
 - IN2 (setpoint)
 - DP communication (for cable lengths > 3.3 ft/1 m); (terminal "MP")
Comply with polarity:
MA = L => SL = L
MA = H => SL = H
 - Ext. Off
 - AUX
 - Communication cable IF-Module

The shield must be applied to both sides: on the EMC cable clips in the module and on the other end. The lines for SBM and SSM do not have to be shielded.

- In order to ensure drip protection and strain relief on the threaded cable connection, cables with a sufficient outer diameter must be used and must be screwed sufficiently tightly. Also, the cables near the threaded cable connection are to be bent to form a drainage loop, to drain any accumulated drips. Position the threaded cable connection or lay the cables accordingly to ensure that no drips can run into the module. Non-assigned threaded cable connections must remain sealed with the plugs provided by the manufacturer.
- The supply cable is to be placed in such a way that under no circumstances can it come into contact with the pipe and/or the pump and motor housing.
- When pumps are used in systems with water temperatures above 90°C / 194°F, a suitably heat-resistant connection line must be used.
- This pump is equipped with a frequency converter and may not be protected by a residual-current-operated protection switch. Frequency converters can impair the function of residual-current-operated protection circuits.

Exception: residual-current-operated protection switches which have a selective type B universal-current-sensitive design are allowed.

- Labeling: RCD  
- Trigger current: > 30 mA
- Check the current type and voltage of the mains connection.
- Observe the name plate information for the pump. The current type and voltage of the mains connection must correspond to the specifications on the name plate.
- Suitable for use on a circuit capable of delivering not more than 5000 rms symmetrical Amperes, 480 V maximum when protected by CC, J or RK5 Class Fuses, rated 20 A.

- Take additional grounding into account!
- The use of a time delay fuse is recommended.
- Internal overload protection operates prior to reaching the 110% of the motor full load.

Terminals

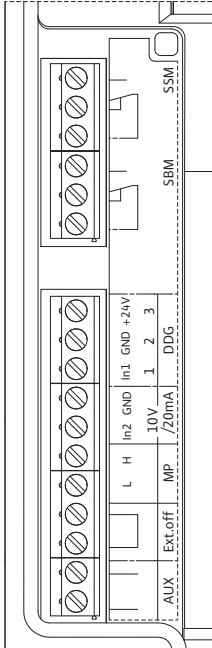

Fig. 26: Control terminals

- Control terminal (Fig. 26).
See following table for assignment.
For details see wiring diagram (Fig. 4).

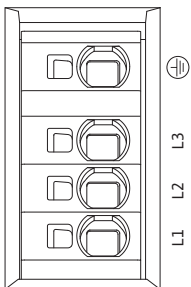

Fig. 27: Power terminals (mains connection terminals)

- Power terminals (mains connection terminals) (Fig. 27).
See following table for assignment.
For details see wiring diagram (Fig. 4).

Connection terminal allocation

Designation	Assignment	Notes
L1, L2, L3	Mains connection voltage	Three-phase current 3~380 V to 3~480 V AC, 50/60 Hz, IEC 38
Ground	Protective conductor connection	
IN1 (1) (input)	Actual value input	Type of signal: Voltage (0–10 V, 2–10 V) Input resistance: $R_i \geq 10 \text{ k}\Omega$ Type of signal: Current (0–20 mA, 4–20 mA) Input resistance: $R_i = 500 \Omega$ Can be configured in the service menu <5.3.0.0> Connected at the factory via the M12 threaded cable connection (Fig. 2), via (1), (2), (3) according to the sensor cable designations (1,2,3).
IN2 (input)	Setpoint input	IN2 can be used as the input for remote setpoint adjustment in all operating modes. Type of signal: Voltage (0–10 V, 2–10 V) Input resistance: $R_i \geq 10 \text{ k}\Omega$ Type of signal: Current (0–20 mA, 4–20 mA) Input resistance: $R_i = 500 \Omega$ Can be configured in the service menu <5.4.0.0>
GND (2)	Ground connections	For both input IN1 and IN2
+ 24 V (3) (output)	DC voltage for an ext. consumer/sensor	Max. load 60 mA. The voltage is short-circuit proof.
AUX	External pump cycling	Pump cycling can be performed using an external, potential-free contact. One-time bridging of the two terminals will cause external pump cycling to take place, if it is enabled. Bridging a second time will cause the procedure to repeat, provided the minimum run time is adhered to. Can be configured in the service menu <5.1.3.2> Contact load: 24 V DC/10 mA
MP	Multi Pump	Interface for dual pump function
Ext. Off	Control input "Overriding off" for external, potential-free switch	The pump can be switched on/off via an external potential-free contact. In systems with a high switching frequency (> 20 on/off operations per day); switching on/off must take place via "Ext. Off". Can be configured in the service menu <5.1.7.0> Contact load: 24 V DC/10 mA
SBM	Individual run signal/collective run signal, readiness signal and mains on signal	Potential-free individual run signal/collective run signal (changeover contact), operation readiness signal is available at the SBM terminals (menus <5.1.6.0>, <5.7.6.0>).
	Contact load:	Permitted minimum: 12 V DC, 10 mA Permitted maximum: 250 V AC/24 V DC, 1 A.
SSM	Individual/collective fault signal	Potential-free single/collective fault signal (changeover contact) is available at the SSM terminals (menu <5.1.5.0>).
	Contact load:	Permitted minimum: 12 V DC, 10 mA Permitted maximum: 250 V AC/24 V DC, 1 A.
Interface IF-Module	Connection terminals of the serial digital BA interface	The optional IF-Module is pushed into a multi-plug in the terminal box. The connection is twist proof.



NOTE:

The terminals IN1, IN2, AUX, GND, Ext. Off and MP meet the requirement for "isolated secondary circuits, limited voltage/limited current" (according to UL508C and EN 61800-5-1) to the mains terminals, as well as to the SBM and SSM terminals (and vice versa).

Differential pressure sensor connection



NOTE:

The control is designed as a PELV (protective extra low voltage) circuit, meaning that the (internal) supply meets the requirements for safe supply isolation; the GND is connected to \perp (Ground)

Cable	Colour	Terminal	Function
1	black	IN1	Signal
2	blue	GND	Ground
3	brown	+24 V	+24 V



NOTE:

The electrical connection of the differential pressure sensor is to be fed through the smallest threaded cable connection (M12) on the module.

For a double pump or Y-pump installation, the differential pressure sensor is to be connected to the master pump.

The measuring points of the differential pressure sensor of the master pump must be on the suction and pressure side of the double-pump system in the corresponding collector pipe.

Procedure

- Establish connections observing the terminal allocation.
- Ground the pump/system according to regulations.

8 Operation

8.1 Operating elements

The electronics module is operated using the following operating elements:

The red button

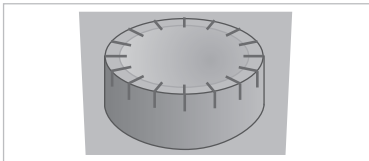

Fig. 28: The red button

The red button (Fig. 28) can be turned to select menu elements and used to change values. Pressing the red button activates a selected menu element and confirms values.

DIP switch

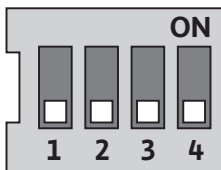

Fig. 29: DIP switch

The DIP switches (Fig. 14, Item 5/Fig. 29) are located under the housing cover.

- Switch 1 is for switching between the standard and service mode. For additional information, see chapter 8.6.6 “Activating/deactivating service mode” on page 36.
- Switch 2 allows activation or deactivation of the “access disable” feature. For additional information, see chapter 8.6.7 “Activating/deactivating access disable” on page 37.
- Switches 3 and 4 permit termination of the multi-pump communication.

For additional information, see chapter 8.6.8 “Activating/deactivating termination” on page 37.

8.2 Display structure

Information appears on the display as shown in the sample illustration below:

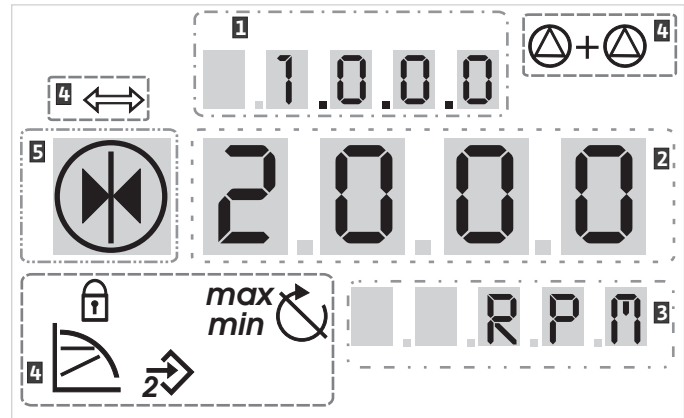

Fig. 30: Display structure

Item	Description	Item	Description
1	Menu number	4	Standard symbols
2	Value display	5	Symbol display
3	Units display		



NOTE:

The display can be rotated by 180°. To change, see menu number <5.7.1.0 >.

8.3 Explanation of standard symbols

The following symbols are shown on the display at the positions shown above:

Symbol	Description	Symbol	Description
	Constant speed control	<i>min</i>	Min operation
	Constant control Δp-c	<i>max</i>	Max. operation
	variable control Δp-v		Pump is running
	PID control		Pump is stopping
	Input In (external setpoint) activated		Pump running in emergency operation
	Access disable		Pump stops in emergency operation
	BMS (Building Management System) is active		DP/MP operating mode: Main/reserve
	DP/MP operating mode: Parallel operation		-

8.4 Symbols in graphics/instructions

Chapter 8.6 “Operating instructions” on page 34 contains graphics that illustrate the operating concept and provide instructions for configuring settings.

In the graphics and instructions, the following symbols are used as simple representations of menu elements or actions:

Menu elements



- **Menu status page:** Standard view on the display.
- **“One level down”:** A menu element that can be used to jump to a lower menu level (e.g. <4.1.0.0> to <4.1.1.0>).
- **“Information”:** A menu element that shows information about the device status or settings that cannot be changed.
- **“Selection/setting”:** A menu element that provides access to a changeable setting (element with menu number <X.X.X.0>).
- **“One level up”:** A menu element that can be used to jump to a higher menu level (e.g. <4.1.0.0> to <4.0.0.0>).
- **Menu error page:** In the event of an error, the current error number is displayed instead of the status page.

Actions



- **Turn red button:** Turn the red button or increase or decrease settings or menu numbers.
- **Press red button:** Press the red button to activate a menu element or confirm a change.
- **Navigate:** Perform the steps that follow to navigate in the menu to the displayed menu number.
- **Wait time:** The remaining time (in seconds) is displayed on the value display until the next state is reached automatically or manual input can be made.
- **Set DIP switch to the OFF position:** Set the DIP switch number “X” under the housing cover to the 'OFF' position.
- **Set DIP switch to the ON position:** Set the DIP switch number “X” under the housing cover to the 'ON' position.

8.5 Display modes

Display test

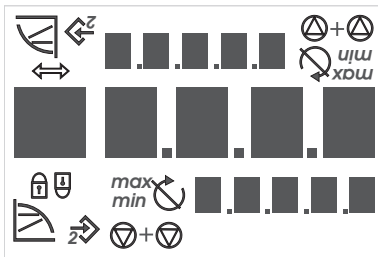



Fig. 31: Display test

As soon as the power supply of the electronic module has been established, a 2-second display test is carried out, during which all characters on the display are shown (Fig. 31). Afterwards the status page is displayed.

After interruption of the power supply, the module carries out various shut-off functions. The display will be shown for the duration of this process.

 **DANGER! Danger of death!**

There can be electrical charges present in the display even if is switched off.

- **Observe general safety instructions!**

8.5.1 Display status page



The standard view on the display is the status page. The current set-point is displayed in the number segments. Other settings are displayed using symbols.



NOTE:

For dual pump operation, the operating mode is also shown in symbol format on the status page ("Parallel operation" or "Main/reserve"). The display of the slave pump shows 'SL'.

8.5.2 Display menu mode

The electronic module functions can be called via the menu structure. The menu contains sub-menus on several levels.

The current menu level can be changed using "One level up" or "One level down" menu items, for example, to change from menu <4.1.0.0> to <4.1.1.0>.

The menu structure is similar to structure of the chapters and sections in these operating instructions: Section 8.5(.0.0) contains subsections 8.5.1(.0) and 8.5.2(.0); in the electronics module, menu <5.3.0.0> contains menu sub-items <5.3.1.0> to <5.3.3.0>, etc.

The currently selected menu element can be identified by the menu number on the display and the associated symbol.

Within a menu level, menu numbers can be selected sequentially by turning the red button.



NOTE:

If the red button is not operated for 30 seconds at any position in menu mode, the display returns to the status page.

Every menu level can contain four different element types:

"One level down" menu element



The "One level down" menu element is indicated on the display by the symbol shown here (arrow on the units display). If a "One level down" menu element is selected, pressing the red button causes a change to the next menu level down. On the display, the new menu level is indicated by a menu number that has increased by one digit as a result of the change; for example, menu <4.1.0.0> changes to menu <4.1.1.0>.

"Information" menu element



The "Information" menu element is marked on the display by the symbol shown here (standard symbol for "access disable"). If an "Information" menu element is selected, pressing the red button has no effect. When an "Information" menu element is selected, current settings or measurements that cannot be changed by the user are displayed.

"One level up" menu element



The "One level up" menu element is indicated on the display by the symbol shown here (arrow on the symbol display). If a "One level up" menu element is selected, briefly pressing the red button causes a change to the next higher menu level. On the display, the new menu level is indicated by the menu number. For example, when one returns from menu level <4.1.5.0>, the menu number jumps to <4.1.0.0>.



NOTE:

If the red button is pressed for two seconds while a "One level up" menu element is selected, the display jumps back to the status page.

“Selection/setting” menu element



The “Selection/setting” menu element does not have a special label on the display, but is identified graphically in these instructions by the adjacent symbol.

If a “Selection/setting” menu element is selected, pressing the red button will change to edit mode. In edit mode, flashing values can be changed by turning the red button.



In some menus, acceptance of the input by pressing the red button will be confirmed by the brief display of the 'OK' symbol.

8.5.3 Display error page

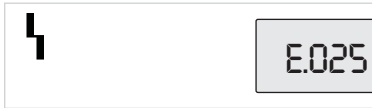

Fig. 32: Error page (status in the event of an error)



If an error occurs, the error page will be shown on the display rather than the status page. The value display shows the letter 'E' and the three-digit error code separated by a decimal point (Fig. 32).

8.5.4 Menu groups

Basic menu

Basic settings are shown in the main menus <1.0.0.0>, <2.0.0.0> and <3.0.0.0>, which provide access to set values that may have to be changed during regular pump operation.

Info menu

The main menu <4.0.0.0> and its sub-menu elements show measuring data, device data, operating data and current states.

Service menu

The main menu <5.0.0.0> and its sub-menu elements provide access to basic system settings for commissioning. The sub-elements are in a write-protected mode as long as service mode is not activated.



CAUTION! Danger of property damage!

Improper setting changes can lead to pump operation errors, which can lead to property damage to the pump or system.

- **Settings in service mode should only be made during commissioning and only by qualified personnel.**

Error acknowledgment menu

In the event of an error, the error page is displayed instead of the status page. Pressing the red button from this position opens the error acknowledgment menu (menu number <6.0.0.0>). Any fault signals present can be acknowledged after a waiting period.



CAUTION! Danger of property damage!

Errors which are acknowledged without their cause having been remedied can result in repeated faults, which could lead to property damage to the pump or system.

- **Only acknowledge errors after they have been remedied.**
- **Only have faults corrected by qualified personnel.**
- **If in doubt, consult the manufacturer.**

For additional information, see chapter 11 “Faults, causes and remedies” on page 57 and the error table shown there.

Access disable menu

The main menu <7.0.0.0> is only displayed when DIP switch 2 is in the ON position. It cannot be reached via normal navigation.

In the “Access disable” menu, the access disable can be activated or deactivated by turning the red button. The change is confirmed by pressing the red button.

8.6 Operating instructions

8.6.1 Adjusting the setpoint

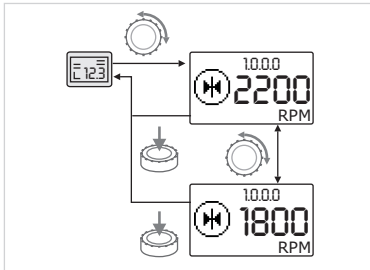

Fig. 33: Entering the setpoint



- Turn the red button.

The display changes to menu number <1.0.0.0>. The setpoint begins to flash and is increased or decreased by continuing to turn.



- To confirm the change, press the red button.

The new setpoint will be accepted and the display will return to the status page.

8.6.2 Changing to menu mode

To change to menu mode, proceed as follows:



- While the display is showing the status page, press the red button for two seconds (except in case of an error).

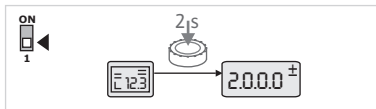

Fig. 34: Standard menu mode

Standard behavior:

The display changes to menu mode. Menu number <2.0.0.0> is displayed (Fig. 34).

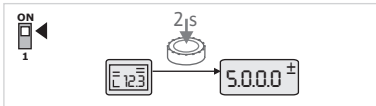

Fig. 35: Service menu mode

Service mode:

If service mode is activated via DIP switch 1 menu number <5.0.0.0> is displayed first. (Fig. 35).

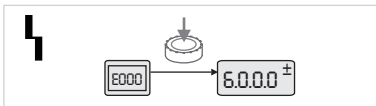

Fig. 36: Error case menu mode

Error case:

In case of error, menu number <6.0.0.0> is displayed (Fig. 36).

8.6.3 Navigation

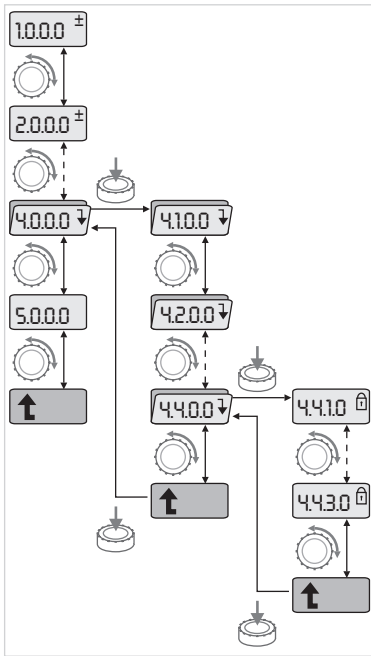

Fig. 37: Navigation example



- Change to menu mode (see 8.6.2 “Changing to menu mode” on page 34).



- Carry out general menu navigation as follows (for an example, see Fig. 37):

During navigation, the menu number flashes.



- To select the menu element, turn the red button.

The menu number is incremented up or down. The symbol associated with the menu element and the setpoint or actual value are shown, if applicable.



- If the downward pointing arrow for “One level down” is shown, press the red button to change to the next level down. On the display, the new menu level is indicated by the menu number, for example, <4.4.0.0> changes to <4.4.1.0>.

The symbol for the menu element and/or the current value (setpoint, actual value or selection) will be shown.



- To return to the next higher menu level, select the “One level up” menu element and press the red button.

On the display, the new menu level is indicated by the menu number, for example, <4.4.1.0> changes to <4.4.0.0>.



NOTE:

If the red button is pressed for two seconds while a “One level up” menu element is selected, the display jumps back to the status page.

8.6.4 Changing selection/settings

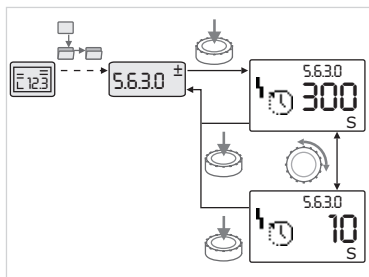

Fig. 38: Setting with return to the “Selection/settings” menu element



- Navigate to the desired “Selection/settings” menu element.

The current value or state of the setting and the associated symbol are displayed.



- Press the red button. The symbol representing the setpoint or the setting flashes.



- Turn the red button until the desired setpoint or setting is displayed. For an explanation of the settings represented by the symbols, see the table in chapter 8.7 “Menu elements reference” on page 37.



- Press the red button again.

The selected setpoint or setting is confirmed, and the value or symbol stops flashing. The display has returned to menu mode with the menu number unchanged. The menu number flashes.

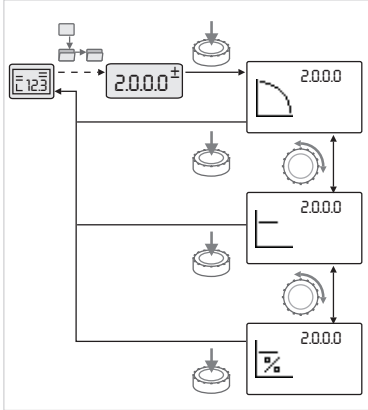

Fig. 39: Setting with return to the status page



NOTE:
When values are changed under <1.0.0.0>, <2.0.0.0> and <3.0.0.0>, <5.7.7.0> and <6.0.0.0>, the display jumps back to the status page (Fig. 39).

8.6.5 Calling up information

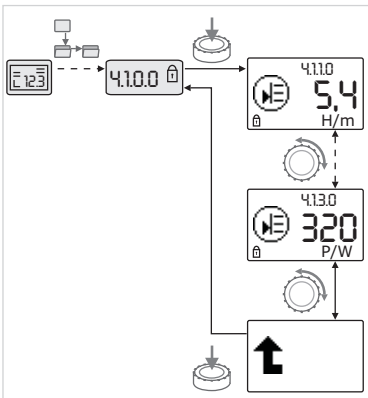

Fig. 40: Calling up information



Changes cannot be made in “Information” menu elements. These are identified on the display by the default “access disable” symbol. To call up current settings, proceed as follows:



- Navigate to the desired “Information” menu element (<4.1.1.0> in the example).



The current value or state of the setting and the associated symbol are displayed. Pressing the red button has no effect.



- Turn the red button to access the “Information” menu elements in the current sub–menu (see Fig. 40). For an explanation of the settings represented by the symbols, see the table in chapter 8.7 “Menu elements reference” on page 37.



- Turn the red button until the “One level up” menu element is displayed.



- Press the red button.

The display returns to the next higher menu level (<4.1.0.0> here).

8.6.6 Activating/deactivating service mode

Additional settings can be made in service mode. The mode is activated or deactivated as follows.



CAUTION! Danger of property damage!

Improper setting changes can lead to pump operation errors, which can lead to property damage to the pump or system.

- **Settings in service mode should only be made during commissioning and only by qualified personnel.**



- Set DIP switch 1 to the 'ON' position.

Service mode is activated. The symbol shown here flashes on the status page.



The sub–elements of menu 5.0.0.0 switch from the “Information” element type to the “Selection/setting” element type, and the standard “access disable” symbol (see symbol) is hidden for the respective elements (except for <5.3.1.0>).

The values and settings for these elements can now be edited.

- To deactivate, return the switch to its starting position.

8.6.7 Activating/deactivating access disable

In order to prevent impermissible changes to the pump settings, all functions can be disabled.



When access is disabled, this is shown on the status page by the default "access disable" symbol.

To activate or deactivate this, proceed as follows:



- Set DIP switch 2 to the 'ON' position.

Menu <7.0.0.0> is displayed.



- Turn the red button to activate or deactivate the disable.



- To confirm the change, press the red button.

The current state of the disable is represented on the symbol display by the symbols shown here.



Disable active

No changes can be made to setpoints or settings. The read access to all menu elements remains as it was.



Disable inactive

The elements of the basic menu can be edited (menu elements <1.0.0.0>, <2.0.0.0> and <3.0.0.0>).

NOTE:

To edit the sub-elements of menu <5.0.0.0>, service mode must also be activated.



- Reset DIP switch 2 to the 'OFF' position.

The display returns to the status page.



NOTE:

Errors can be acknowledged after a waiting period despite the "access disable" being active.

8.6.8 Activating/deactivating termination

In order to establish a definite communication connection between the modules, it is necessary to terminate both ends of the cable.

In a double pump, the modules are already prepared for double pump communication at the factory.

To activate or deactivate this, proceed as follows:



- Set DIP switches 3 and 4 to the 'ON' position.

Termination is activated.



NOTE:

Both DIP switches must always be in the same position.

- To deactivate, return the switches to the starting position.

8.7 Menu elements reference

The following table gives an overview of the available elements of all menu levels. The menu number and the element type are designated separately, and the function of the element is explained. If applicable, there is information about the setting options of the individual elements.



















































NOTE:

























A few elements are hidden under certain conditions and are therefore skipped in the menu navigation.



































If, for example, the external setpoint adjustment under menu number <5.4.1.0> is set to 'OFF', the number <5.4.2.0> will be hidden. Menu number <5.4.2.0> will only be visible if menu number <5.4.1.0> has been set to 'ON'.

































The condition for hiding a menu element is explained in the last column of the table.

No.	Designation	Type	Symbol	Values/explanations	Display conditions
1.0.0.0	Setpoint			Setting/display of the setpoint (for further information, see chapter 8.6.1 "Adjusting the setpoint" on page 34)	
2.0.0.0	Control mode			Setting/display of the control mode (for further information, see chapters 9.4 "Setting the control mode" on page 47 and 6.2 "Control modes" on page 13)	
				Constant speed control	
				Constant Δp -c control	
				Variable Δp -v control	
				PID control	
3.0.0.0	Pump on/off			ON Pump switched on	
				OFF Pump switched off	
4.0.0.0	Information			Information menus	
4.1.0.0	Actual values			Display of current actual values	
4.1.1.0	Actual values sensor (IN1)			Depending on current control mode. Δp -c, Δp -v: Value H in ft PID control: Value in %	Not displayed for manual control mode
4.1.2.0	Switching frequency			HIGH High switching frequency (factory setting)	Switchover/modification must only be carried out when pump is at standstill (motor not running)
				MID Medium switching frequency	
				LOW Low switching frequency	
4.1.3.0	Power			Current power input P_1 in W	
4.2.0.0	Operating data			Display of operating data	The operating data refer to the module currently being operated
4.2.1.0	Operating hours			Sum of the pump's active hours of operation (counter can be reset by infrared interface)	







No.	Designation	Type	Symbol	Values/explanations	Display conditions
4.2.2.0	Consumption			Energy consumption in kWh/MWh	
4.2.3.0	Countdown, pump cycling			Time to pump cycling in h (at a resolution of 0.1 h)	Shown only for DP-MA and internal pump cycling. Can be set in the service menu <5.1.3.0>
4.2.4.0	Remaining time until pump exercise			Time until the next pump exercise (after the pump has had a 24 h standstill (e.g. via Ext. off), it will be automatically operated for 5 seconds)	
4.2.5.0	Mains on counter			Number of switching-on procedures of the supply voltage (each occasion the supply voltage is established after an interruption is counted)	
4.2.6.0	Pump exercise counter			Number of pump exercises carried out	
4.3.0.0	States				
4.3.1.0	Base-load pump			The value display statically shows the identity of the regular base-load pump. The unit display statically shows the identity of the temporary regular base-load pump.	Only displayed in DP-MA mode
4.3.2.0	SSM		  	ON State of the SSM relay if there is no fault signal	
			  	OFF State of the SSM relay if no fault signal is present	
4.3.3.0	SBM			ON State of the SBM relay if a readiness/operation or "mains on" signal is present	
				OFF State of the SBM relay if no readiness/operation or "mains on" signal is present	

No.	Designation	Type	Symbol	Values/explanations	Display conditions
			  	SBM Run signal	
			  	SBM Readiness signal	
				SBM Mains on signal	
4.3.4.0	Ext. Off		  	Signal present at the input "Ext. off"	
			  	OPEN Pump is switched off	
			  	SHUT Pump is enabled for operation	
4.3.5.0	BMS protocol type			Bus system active	Only displayed when BMS is active
				LON field bus system	Only displayed when BMS is active
				CAN field bus system	Only displayed when BMS is active
				Gateway Protocol	Only displayed when BMS is active
4.4.0.0	Device data			Displays device data	

No.	Designation	Type	Symbol	Values/explanations	Display conditions
4.4.1.0	Pump name			Example: Stratos GIGA 1.5/3-165 (display in ticker format)	Only the basic pump model appears on the display; version names are not shown.
4.4.2.0	Software version of user controller			Displays the software version of the user controller.	
4.4.3.0	Software version of motor controller			Display the software version of the motor controller	
5.0.0.0	Service			Service menus	
5.1.0.0	Multi pump			Double pump	Only displayed when DP is active (incl. sub-menus)
5.1.1.0	Operating mode			Main/standby operation	Only displayed in DP-MA mode
				Parallel operation	Only displayed in DP-MA mode
5.1.2.0	Setting, MA/SL			Manual converting from master to slave mode	Only displayed in DP-MA mode
5.1.3.0	Pump cycling				Only displayed in DP-MA mode
5.1.3.1	Manual pump cycling			Carries out pump cycling independent of the countdown	Only displayed in DP-MA mode
5.1.3.2	Internal/external			Internal pump cycling	Only displayed in DP-MA mode
				External pump cycling	Only displayed in DP-MA mode, see "AUX" terminal
5.1.3.3	Internal: Time interval			Can be set between 8 hours and 36 hours in 4-hour increments	Displayed when internal pump cycling is activated
5.1.4.0	Pump enabled/disabled			Pump enabled	
				Pump disabled	
5.1.5.0	SSM			Individual fault signal	Only displayed in DP-MA mode
				Collective fault signal	Only displayed in DP-MA mode
5.1.6.0	SBM			Individual readiness signal	Is only displayed with DP-MA and SBM function at readiness/operation
				Individual run signal	Only displayed in DP-MA mode
				Collective readiness signal	Only displayed in DP-MA mode
				Collective run signal	Only displayed in DP-MA mode
5.1.7.0	External Off			Individual external Off	Only displayed in DP-MA mode
				Collective external Off	Only displayed in DP-MA mode

No.	Designation	Type	Symbol	Values/explanations	Display conditions
5.2.0.0	BMS			Settings for Building Management System (BMS) – building automation	Incl. all sub-menus, only displayed when BMS is active
5.2.1.0	LON/CAN/IF-Modul Wink/service			The wink function permits the identification of a device in the BMS network. A "wink" is executed by confirmation.	Only displayed when LON, CAN or IF-Module is active
5.2.2.0	Local/remote operation			BMS local operation	Temporary state, automatic reset to remote operation after 5 min
				BMS remote operation	
5.2.3.0	Bus address			Setting of bus address	
5.2.4.0	IF gateway val A			Specific settings of the IF-Module, depends on protocol type	Further information can be found in the installation and operating instructions of the IF-Modules
5.2.5.0	IF gateway val C			Specific settings of the IF-Module, depends on protocol type	Further information can be found in the installation and operating instructions of the IF-Modules
5.2.6.0	IF gateway val E			Specific settings of the IF-Module, depends on protocol type	Further information can be found in the installation and operating instructions of the IF-Modules
5.2.7.0	IF gateway val F			Specific settings of the IF-Module, depends on protocol type	Further information can be found in the installation and operating instructions of the IF-Modules
5.3.0.0	IN1 (sensor input)			Settings for sensor input 1	Not displayed in the manual control mode (incl. all sub-menus)
5.3.1.0	IN1 (sensor value range)			Display of sensor value range 1	Not displayed with PID control
5.3.2.0	IN1 (value range)			Setting of the value range Possible values: 0...10 V/2...10 V/ 0...20 mA/4...20 mA	
5.4.0.0	IN2			Setting for external setpoint input 2	
5.4.1.0	IN2 active/inactive			ON External setpoint input 2 active	
				OFF External setpoint input 2 inactive	
5.4.2.0	IN2 (value range)			Setting of the value range Possible values: 0...10 V/ 2...10 V/0...20 mA/4...20 mA	Not displayed when IN2 = inactive
5.5.0.0	PID parameters			Settings for PID control	Only displayed when PID control is active (incl. all sub-menus)

No.	Designation	Type	Symbol	Values/explanations	Display conditions
5.5.1.0	P parameter			Setting of the proportional term of the control	
5.5.2.0	I parameter			Setting of the integral term of the control	
5.5.3.0	D parameter			Setting of the derivative term of the control	
5.6.0.0	Error			Settings for behavior in case of error	
5.6.1.0	HV/AC			HV "heating" mode	
				AC "cooling/air-conditioning" mode	
5.6.2.0	Emergency operation speed			Display of emergency operation speed	
5.6.3.0	Auto reset time			Time until automatic acknowledgment of an error	
5.7.0.0	Other settings				
5.7.1.0	Display orientation			Display orientation	
				Display orientation	
5.7.2.0	Pressure value correction			When pressure value correction is enabled, the differential pressure deviation measured by the differential pressure sensor that is factory-fitted on the pump flange is taken into account and corrected.	Only displayed in Δp -c mode. Is not displayed for all pump variants.
				Pressure value correction off	
				Pressure value correction on	
5.7.6.0	SBM function			Setting for behavior of signals	
				SBM run signal	
				SBM readiness signal	
				SBM mains on signal	
5.7.7.0	Factory setting			OFF (default setting) Settings are not changed by confirming.	Is not displayed when "access disable" is active. Is not displayed when building management system active.

No.	Designation	Type	Symbol	Values/explanations	Display conditions
				ON Confirming will reset the settings to factory settings. Caution! All manual settings will be lost.	Is not displayed when "access disable" is active. Is not displayed when building management system active.
6.0.0.0	Error acknowledgment			For additional information, see chapter 11.3 "Acknowledging errors" on page 59.	Only displayed if an error is present
7.0.0.0	Access disable			"Access disable" inactive (changes possible) (for further information, see chapter 8.6.7 "Activating/deactivating access disable" on page 37).	
				"Access disable" active (no changes possible) (for further information, see chapter 8.6.7 "Activating/deactivating access disable" on page 37).	

9 Commissioning

Safety



DANGER! Danger of death!

Failure to install safety devices of the electronic module and the motor can cause electrical shock or contact with rotating parts, potentially resulting in life-threatening injuries.

- Before commissioning as well as after maintenance work, all safety devices such as module covers and fan cover that were removed must be reinstalled.
- Keep a safe distance during commissioning!
- Never connect the pump without the module.

Preparation

Before commissioning, the pump and module must be at ambient temperature.

9.1 Filling and bleeding

- Prime and bleed the system as required.



CAUTION! Damage to the pump!

Dry running will destroy the mechanical seal.

- Make sure that the pump does not run dry.

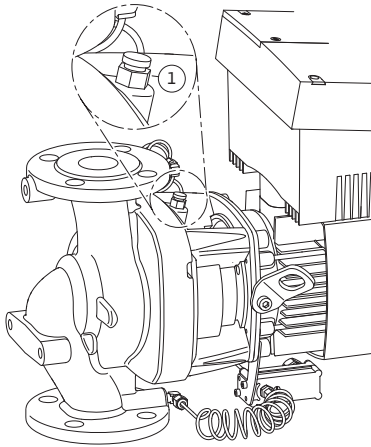

Fig. 41: Bleed valve

- To avoid cavitation noise and damage, a minimum inlet pressure must be guaranteed at the suction port of the pump. This minimum inlet pressure depends on the operating situation and the duty point of the pump, and must be defined accordingly.
- The main parameters for defining the minimum intake pressure are the NPSH of the pump at its duty point and the vapor pressure of the fluid.
- Bleed the pumps by releasing the bleed valves (Fig. 41, Item 1). Dry running destroys the mechanical seal of the pump. The differential pressure sensor must not be bled (risk of destruction).



WARNING! Danger due to extremely hot or extremely cold pressurized fluid!

Depending on the temperature of the fluid and the system pressure, when the vent screw is opened completely, extremely hot or extremely cold fluid in liquid or vapor form may escape or shoot out at high pressure.

- Always exercise caution when opening the vent screw.
- Protect the module box from any water escaping when bleeding.



WARNING! Danger of death!

Falling pumps or pump parts may result in life-threatening injuries.

- When performing installation work, protect the pump components against falling.



WARNING! Danger of burns or freezing to the pump when body parts come into contact with the pump!

Depending on the pump or system operating conditions (fluid temperature), the entire pump can become very hot or very cold.

- Keep a safe distance during operation!
- Allow the pump/system to cool off/warm up before performing any work.
- Always wear protective clothing, protective gloves and protective goggles when working.



WARNING! Danger of injury!

If the pump/system is installed improperly, liquid may be ejected during commissioning. Individual components may also become loose.

- Keep a safe distance from the pump during commissioning.
- Wear protective clothing, protective gloves and protective goggles.

9.2 Double pump installation/Y-pump installation

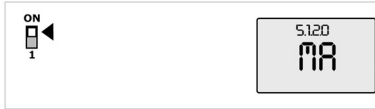

Fig. 42: Setting the master pump



NOTE:

For the initial commissioning of a Y-pump installation that has not been preconfigured, both pumps are set to their factory setting. After connecting the double pump communication cable, the fault code 'E035' is displayed. Both drives run at the emergency operation speed.

On acknowledgment of the error message, menu <5.1.2.0> is displayed and 'MA' (= master) flashes. In order to acknowledge 'MA', "access disable" must be deactivated and service mode must be active (Fig. 42).

Both pumps are set to "master" and 'MA' flashes on the displays of both electronic modules.

- Acknowledge one of the two pumps as master pump by pressing the red button. The status 'MA' appears on the display of the master pump. The differential pressure sensor must be connected on the master. The measuring points of the differential pressure sensor of the master pump must be on the suction and pressure side of the double-pump system in the corresponding collector pipe.

The other pump will then display the status 'SL' (= slave pump).

All further pump settings must now be made via the master only.



NOTE:

The procedure can be manually started later by selecting the menu <5.1.2.0>.

(For information about navigation in the service menu, see 8.6.3 "Navigation" on page 35).

9.3 Setting the pump output

- The system was designed for a certain duty point (full load point, calculated maximum heating capacity requirement). During commissioning, the pump output (delivery head) must be set according to the duty point of the system.
- Factory settings do not comply with the pump output required for the system. It is determined with the help of the pump curve diagram for the selected pump type (from catalogue/data sheet).



NOTE:

The flow value shown on the IR-Monitor display or output to the building management system must not be used to control the pump. This value is merely an indicator of general trends.

A flow value is not output on every type of pump.



CAUTION! Danger of property damage!

An inadequate volume flow can lead to damage on the mechanical shaft seal; the minimum volume flow depends on the rotation speed of the pump.

- **Make sure that the volume flow does not go below the minimum value Q_{min} .**
- **Calculation of Q_{min} :**

$$Q_{min} = 10\% \times Q_{max \text{ pump}} \times \frac{\text{Actual speed}}{\text{Max. speed}}$$

9.4 Setting the control mode

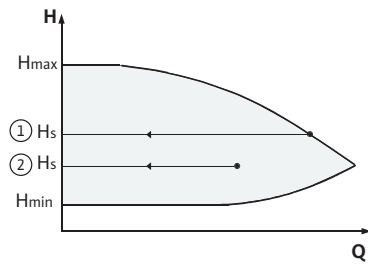

Fig. 43: $\Delta p\text{-c}/\Delta p\text{-v}$ control

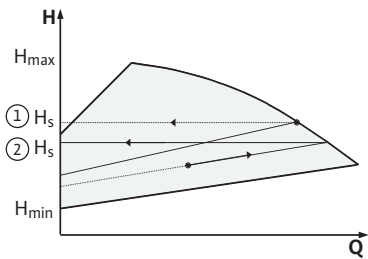
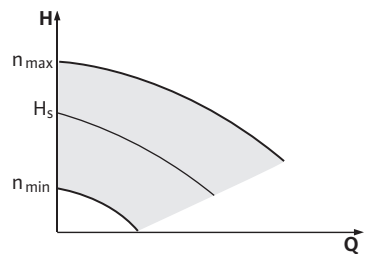

Fig. 44: Manual control mode



$\Delta p\text{-c}/\Delta p\text{-v}$ control:

Setting (Fig. 43)	$\Delta p\text{-c}$	$\Delta p\text{-v}$
① Duty point on maximum pump curve	Draw from duty point towards the left. Read off setpoint H_s and set the pump to this value.	Draw from duty point towards the left. Read off setpoint H_s and set the pump to this value.
② Duty point within the control range	Draw from duty point towards the left. Read off setpoint H_s and set the pump to this value.	Move to max. pump curve along control curve, then horizontally to the left, read off setpoint H_s and set the pump to this value.
Adjustment range	H_{\min} , H_{\max} see pump curves (in catalogue, select or online)	H_{\min} , H_{\max} see pump curves (in catalogue, select or online)



NOTE:

Alternatively, manual control mode (Fig. 44) or PID operating mode can also be set.

Manual control mode:

“Manual control” mode deactivates all other control modes. The speed of the pump is kept to a constant value and set using the rotary knob.

The speed range is dependent on the motor.

PID control:

The PID controller in the pump is a standard PID controller, as described in control engineering literature. The controller compares a measured process value to a predefined setpoint and attempts to adjust the process value to match the setpoint as closely as possible. Provided appropriate sensors are used, a variety of control systems (including pressure, differential pressure, temperature and flow control) can be realized.

When selecting a sensor, keep in mind the electrical values presented in the table titled “Connection terminal allocation” on page 28.

The control behavior can be optimized by adjusting the P, I and D parameters. The P (or proportional) term of the controller contributes a linear gain of the deviation between the process (actual) value and the setpoint to the controller output. The sign of the P term determines the controller’s direction of action.

The I (or integral) term of the controller provides integral control based on the system deviation. A constant deviation results in a linear increase at the controller output. Hence a continuous system deviation is avoided.

The D (or derivative) term responds directly to the rate of change of the system deviation. This affects the rate at which the system responds. In the factory settings, the D term is set to zero, since this is an appropriate setting for a number of applications.

These parameters should only be changed in small increments, and the effects on the system should be monitored continuously. Para-

meter values should only be tuned by someone with training in control engineering.

Control portion	Factory setting	Adjustment range	Increment
P	0.5	-30.0 ... -2.0	0.1
		-1.99 ... -0.01	0.01
		0.00 ... 1.99	0.01
		2.0 ... 30.0	0.1
I	0.5 s	10 ms ... 990 ms	10 ms
		1 s ... 300 s	1 s
D	0 s (= deactivated)	0 ms ... 990 ms	10 ms
		1 s ... 300 s	1 s

The direction of action of the controller is determined by the sign of the P term.

Positive PID control (default):

If the sign of the P term is positive and the process value drops below the setpoint, the control will increase the pump speed until the setpoint has been reached.

Negative PID control:

If the sign of the P term is negative and the process value drops below the setpoint, the control will decrease the pump speed until the setpoint has been reached.



NOTE:

Check the controller's direction of action if PID control is being used, but the pump is only running at minimum or maximum speed without responding to changes in the parameter values.

10 Maintenance

Safety

Have maintenance and repair work carried out by qualified personnel only!

It is recommended to have the pump serviced and checked by WILO Customer Service.



DANGER! Danger of death!

There is a mortal danger through shock when working on electrical equipment.

- Work on electrical equipment may only be done by electricians approved by the local electricity supplier.
- Before working on electrical equipment, switch it off and prevent it from being switched on again.
- Any damage to the connecting cable should always be rectified by a qualified electrician only.
- Never use an object to poke around the openings on the module or motor and never insert anything into the module or motor!
- Follow the installation and operating instructions for the pump, level control and other accessories.

**DANGER! Danger of death!**

The permanently magnetized rotor inside the motor presents an acute danger to persons with pacemakers. Non-observance results in death or very serious injuries.

- Do not open the motor!
- Only allow Wilo customer service to dismantle and install the rotor for maintenance and repair work.

**WARNING! Danger of personal injury!**

Opening the motor leads to high, suddenly occurring magnetic forces. These can cause serious cuts, crushing injuries and bruises.

- Do not open the motor!
- Only allow Wilo customer service to dismantle and install the motor flange and the end shield for maintenance and repair work.

**DANGER! Danger of death!**

Failure to install safety devices at the module and at the motor can cause electrical shock or contact with rotating parts, potentially resulting in life-threatening injuries.

- After maintenance, all safety devices (such as module and fan covers) that were removed must be reinstalled!

**CAUTION! Danger of property damage!**

Danger of damage due to incorrect handling.

- The pump may never be operated without the module being installed.

**DANGER! Danger of death!**

The pump itself and the parts of pump can be extremely heavy. Falling parts pose a risk of cuts, crush injuries, bruises or impacts, which may lead to death.

- Always use suitable lifting equipment and secure parts against falling.
- Never stand underneath a suspended load.
- Make sure the pump is securely positioned and is stable during storage and transport as well as prior to all installation and other assembly work.

**DANGER! Danger of burns or freezing to the pump when body parts come into contact with the pump!**

Depending on the pump or system operating conditions (fluid temperature), the entire pump can become very hot or very cold.

- Keep a safe distance during operation!
- In the case of high water temperatures and system pressures, allow the pump to cool down before all work.
- Always wear protective clothing, protective gloves and protective goggles when working.

**DANGER! Danger of death!**

The tools used during maintenance work on the motor shaft (such as an open-end wrench) can be flung out if they come into contact with rotating parts and cause serious or even fatal injuries.

- The tools used during maintenance work must be removed completely before the pump is started up.
- If the transport eyes are moved from the motor flange to the motor housing, they must be resecured to the motor flange following the installation or maintenance work.

10.1 Air supply

After the completion of all maintenance work, reattach the fan cover with the provided screws so that the motor as well as the electronic module are sufficiently cooled.

The air supply to the motor housing must be checked at regular intervals. In case of contamination, ensure that an air supply is reestablished in order to allow the both the motor and the module to cool sufficiently.

10.2 Maintenance work**DANGER! Danger of death!**

Falling pumps or pump parts may result in life-threatening injuries.

- When performing installation work, protect the pump components against falling.

**DANGER! Danger of death!**

There is a mortal danger through shock when working on electrical equipment. Following removal of the module, a potentially fatal shock voltage may be present at the motor contacts.

- Check for absence of voltage and cover or cordon off adjacent live parts.

10.2.1 Replacing the mechanical seal

During the running-in period, a minor amount of dripping is to be expected. A visual inspection should be performed from time to time, however. If there is clearly detectable leakage, the seal must be changed.

Wilo offers a repair kit which contains the necessary parts for replacement.

Dismantling

1. Disconnect the system from the power supply and secure it against being switched on again.
2. Close the check valves in front of and behind the pump.
3. Make sure it is not live.
4. Ground the work area and short-circuit.
5. Disconnect the power cable.

**DANGER! Danger of scalding!**

Due to high fluid temperatures there is a risk of scalding.

- If the pump fluid is hot, allow it to cool down before performing any work.

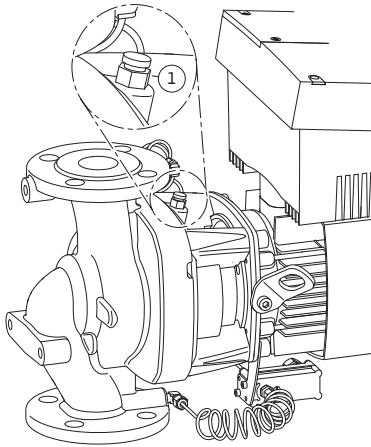

Fig. 45: Bleed valve

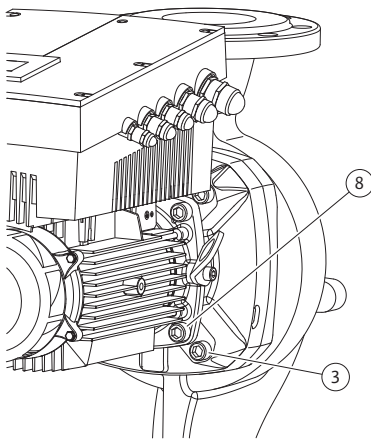

Fig. 46: Optional fixation of the motor impeller unit

6. Depressurize the pump by opening the bleed valve (Fig. 45 Item 1).
7. Loosen the screws (Fig. 7, Item 1) and pull off the fan cover (Fig. 7, Item 2) axially from the motor.
8. The spacers are to be turned out of the two drilled holes of the transport eyes (Fig. 7, Item 20b). Be sure to keep the spacers or screw them into the empty drilled holes after moving the transport eyes (see step 9) (Fig. 7, Item 20a).
9. Remove the two transport eyes (Fig. 7, Item 20) from the motor flange (Fig. 7, Item 20a) and attach them with the same screws to the motor housing (Fig. 7, Item 20b).
10. Attach the motor impeller unit to the transport eyes with suitable lifting equipment for the purpose of safeguarding.



NOTE:

When attaching the lifting equipment, avoid damaging the plastic parts, such as the fan wheel and module upper part.

11. Loosen and remove the screws (Fig. 7, Item 3). Depending on the pump type, the outer screws (Fig. 46, Item 3) are to be taken out. The motor impeller unit (see Fig. 13) remains securely in the pump housing after the removal of the screws; there is no danger of tipping even in the horizontal position of the motor shaft.



NOTE:

An offset screwdriver or socket wrench with ball coupling is best suited for unscrewing of the screws (Fig. 7, Item 3), especially for the pump types with limited space available. It is recommended to use two mounting bolts (see chapter 5.4 "Accessories" on page 10) instead of two screws (Fig. 7, Item 3) which are screwed in diagonally to each other in the pump housing (Fig. 7, Item 14). The mounting bolts make it easier to avoid damaging the impeller when dismantling the motor impeller unit and then reinstalling it.

12. When the screws (Fig. 7, Item 3) are removed, the differential pressure sensor will also be released from the motor flange. Allow the differential pressure sensor (Fig. 7, Item 5) with the holder (Fig. 7, Item 6) to be suspended at the pressure measurement lines (Fig. 7, Item 13).
Disconnect the connecting cable of the differential pressure sensor in the electronic module.

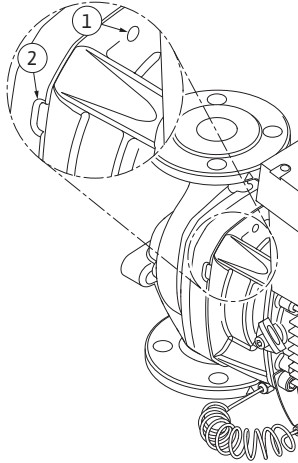

Fig. 47: Threaded holes and slots for pressing off the motor impeller unit from the pump housing

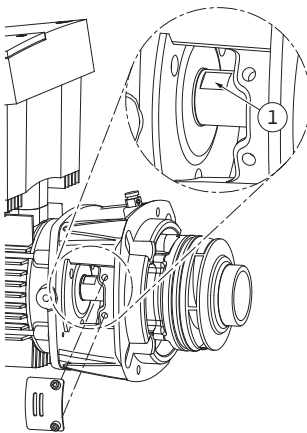

Fig. 48: Wrench surfaces on the shaft

Installation



NOTE:

When pressing out further, the motor impeller unit (see Fig. 13) must, if necessary, be supported by lifting equipment to prevent possible tipping (especially if no mounting bolts are used).

14. Release the two captive screws at the protective plate (Fig. 7, Item 18), and remove the protective plate.
15. Put an open-end wrench (0.9 in/22 mm is the best size) into the lantern window and hold the shaft steady with the wrench surfaces (Fig. 48, Item 3). Unscrew the impeller nut (Fig. 7, Item 15). The impeller (Fig. 7, Item 16) is automatically pulled off the shaft.
16. Depending on the pump type, loosen the screws (Fig. 7, Item 10) or alternatively, the screws (Fig. 46, Item 8).
17. Release the lantern by using the two-arm pull-off-tool (universal pull-off-tool) from the motor centering device and pull it off the shaft. The mechanical seal (Fig. 7, Item 12) will also be removed when this is done. Prevent the lantern from being canted.
18. Press the mechanical seal's counter ring (Fig. 7, Item 17) out of the seat in the lantern.
19. Carefully clean the seating areas of the shaft and the lantern.



NOTE:

For the following steps, observe the screw tightening torque specified for the respective thread type (see Tab. 2 "Screw tightening torques"). Be sure to use a calibrated torque wrench.

20. Clean the flange support and centering surfaces of the pump housing, lantern and motor flange to ensure proper positioning of the parts.
21. Insert a new counter ring in the lantern.
22. Carefully push the lantern over the shaft and position it in the old position or another desired angular position to the motor flange. Observe the permitted installation positions of the components

when doing this (see chapter 7.1 “Permitted installation positions and change of the arrangement of components before the installation” on page 21). Attach the lantern with the screws (Fig. 7, Item 10) **or** – for the pump/lantern types in accordance with (Fig. 46) – with the screws (Fig. 46, Item 8) at the motor flange.

23. Push the new rotating unit of the mechanical seal (Fig. 7, Item 12) onto the shaft.



CAUTION! Danger of property damage!

Danger of damage due to incorrect handling.

- **The impeller is attached with a special nut whose assembly requires a particular procedure described below. If the installation instructions are not observed, there is a danger of overscrewing the thread or of harming the pumping function. The removal of damaged parts can be very difficult and lead to damaging of the shaft.**
- **Apply thread paste to both impeller nut threads for every installation. The thread paste has to be suitable for stainless steels and for the permitted operating temperature of the pump (e.g. Molykote P37). Dry assembly can lead to thread seizing (cold welding) of the thread and make the next dismantling impossible.**

24. During the assembly of the impeller, put an open-end wrench (0.9 in/22 mm is the best size) into the lantern window and hold the shaft steady with the wrench surfaces (Fig. 48, Item 1).

25. Screw the impeller nut into the impeller hub as far as it will go.

26. Tighten the impeller together with the impeller nut on the shaft **by hand** without changing the position achieved in the previous step. Do not use a tool to tighten the impeller.

27. Hold the impeller and manually loosen the impeller nut by about two rotations.

28. Without changing the position achieved in the previous step 27, tighten the impeller together with the impeller nut on the shaft again until increasing friction resistance occurs.

29. Hold on to the shaft (see step 24) and tighten the impeller nut with the specified tightening torque (see Tab. 2 “Screw tightening torques”). The nut (Fig. 49, Item 1) has to be about ± 0.02 in (± 0.5 mm) flush with the end of the shaft (Fig. 49, Item 2). If this is not the case, release the nut and repeat steps 25 to 29.

30. Remove the open-end wrench and reinstall the protective plate (Fig. 7, Item 18).

31. Clean the lantern groove and insert the new O-ring (Fig. 7, Item 11).

32. Attach the motor impeller unit to the transport eyes with suitable lifting equipment for the purpose of safeguarding. When attaching, avoid damaging plastic parts, such as the fan wheel and the upper part of the electronic module.

33. Insert the motor impeller unit (see Fig. 13) into the pump housing in the old position or another desired angular position. Observe the permitted installation positions of the components when doing this (see chapter 7.1 “Permitted installation positions and change of the arrangement of components before the installation” on page 21).

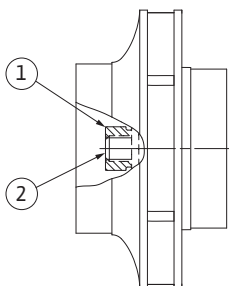

Fig. 49: Correct position of the impeller nut after the installation

The use of mounting bolts is recommended (see chapter 5.4 “Accessories” on page 10). After the lantern guide has been firmly locked into place (about 0.6 in/15 mm) before the end position), there is no longer any danger of tipping or canting. After the motor impeller unit has been secured with at least one screw (Fig. 7, Item 3), the attaching material can be removed from the transport eyes.

34. Screw in the bolts (Fig. 7, Item 3) but do not tighten them all the way. When screwing in the bolts, the motor impeller unit will be pulled into the pump housing.



CAUTION! Danger of property damage!

Danger of damage due to incorrect handling.

- **While screwing in the bolts, ensure that the shaft can be turned by turning the fan wheel a bit. If the shaft is difficult to move, tighten the screws alternately and diagonally.**

35. Screw the two bolts (Fig. 7, Item 21) back in if they were removed. Clamp in the holder (Fig. 7, Item 6) of the differential pressure sensor under one of the screw heads (Fig. 7, Item 3) on the side opposite the electronic module. Then tighten the screws (Fig. 7, Item 3) for the last time.
36. Remove the spacers from the drilled holes at the motor flange (Fig. 7, Item 20a) if necessary and move the transport eyes from the motor housing (Fig. 7, Item 20b) to the motor flange. Screw the spacers back into the drilled holes in the motor housing.
37. Push the fan cover (Fig. 7, Item 2) onto the motor again and attach with the screws (Fig. 7, Item 1) at the module.



NOTE:

Observe the measures for commissioning (chapter 9 “Commissioning” on page 44).

38. Clamp the connecting cable of the differential pressure sensor/ power cable back on if it was disconnected.
39. Open the check valves in front of and behind the pump.
40. Reset the fuse.

Screw tightening torques

Part	Fig./Item Screw (nut)	Thread	Screw head Type...	Tightening torque lbf.ft ± 10% / lb.in ± 10% (Nm ± 10%) (if not otherwise specified) (1 ft = 12 in)	Installation information
Transport eyes	Fig. 7/Item 20	M8	Hexagon socket 0.25 in (6 mm)	15/180 (20)	
Motor impeller unit	Fig. 7/Item 3 Fig. 44/Item 3	M12	Hexagon socket 0.4 in (10 mm)	44/528 (60)	See chap.10.2.1 "Replacing the mechanical seal" on page 50.
Lantern	Fig. 7/Item 10 Fig. 44/Item 8	M6 M10	Hexagon socket 0.2 in (5 mm) Hexagon socket 0.3 in (8 mm)	5/60 (7) 30/360 (40)	
Impeller	Fig. 7/Item 15	Special nut	Hexagon head 0.7 in (17 mm)	15/180 (20)	See chap.10.2.1 "Replacing the mechanical seal" on page 50. Open-end wrench, shaft: 0.9 in (22 mm)
Protective plate	Fig. 7/Item 18	M5	Hexagon head 0.3 in (8 mm)	3/36 (3.5)	
Fan cover	Fig. 7/Item 1	Special screw	Hexagon socket 0.12 in (3 mm)	$3^{+0.37}/36^{+4.44}$ (4+0.5)	
Electronic module	Fig. 7/Item 22	M5	Hexagon socket 0.16 in (4 mm)	1.5/18 (2)	
Module cover	Fig. 3		Phillips recessed head PZ2	0.6/7.2 (0.8)	
Control terminals	Fig. 12/Item 4		Slotted-head screw 0.14 x 0.02 in (3.5 x 0.6 mm)	$0.4^{+0.07}/$ $4.8^{+0.84}$ (0.5+0.1)	
Power terminals	Fig. 12/Item 7		Slotted-head screw SFZ 1-0.02 x 0.14 in (SFZ 1-0.6 x 3.5 mm)	0.4/4.8 (0.5)	Plugging of the cable without tools. Releasing of the cable with a screw- driver.
Union nut, cable lead-throughs	Fig. 2	M12x1.5 NPT 1/4" NPT 1/2" NPT 3/4"	Hexagon head 0.6 in (14 mm) Hexagon head 0.7 in (17 mm) Hexagon head 0.9 in (22 mm) Hexagon head 1.1 in (27 mm)	2/24 (3) 4/48 (6) 6/72 (8) 8/96 (11)	M12x1.5 is reserved for con- nection line of the series sensor only

Tab. 2 Screw tightening torques

10.2.2 Replacing the motor

- Carry out steps 1 to 19 to dismantle the motor in accordance with chapter 10.2 “Maintenance work” on page 50.
- Remove the screws (Fig. 7, Item 21) and pull the electronic module vertically upwards (Fig. 7).
- Before reinstalling the electronic module, pull the new O-ring between the module (Fig. 7, Item 22) and the motor (Fig. 7, Item 4) onto the contacting chamber.
- Press the electronic module into the contacting of the new motor and fasten with screws (Fig. 7, Item 21).
- Carry out steps 20 to 40 to install the motor in accordance with chapter 10.2 “Maintenance work” on page 50.



DANGER! Danger of death!

There is a mortal danger through shock when working on electrical equipment. Following removal of the module, a potentially fatal shock voltage may be present at the motor contacts.

- **Check for absence of voltage and cover or cordon off adjacent live parts.**



NOTE:

Increased bearing noise and unusual vibrations are a sign of bearing wear. Then the bearing has to be changed by Wilo customer service.



WARNING! Danger of personal injury!

Opening the motor leads to high, suddenly occurring magnetic forces. These can cause serious cuts, crushing injuries and bruises.

- **Do not open the motor!**
- **Only allow Wilo customer service to dismantle and install the motor flange and the end plate for maintenance and repair work.**

10.2.3 Replacing electronic module



DANGER! Danger of death!

If the rotor is driven by the impeller when the pump is in standstill, dangerous contact voltage can arise at the motor contacts.

- **Close the shut-off device in front of and behind the pump.**

- Carry out steps 1 to 7 to dismantle the electronic module in accordance with chapter 10.2 “Maintenance work” on page 50.
- Remove the screws (Fig. 7, Item 21) and pull the module from the motor.
- Replace the O-ring.
- Installation in reverse order.



NOTE:

The module has to be pressed on as far as possible when it is installed.

10.2.4 Replacing the fan wheel

Carry out steps 1 to 7 to dismantle the fan wheel in accordance with chapter 10.2 “Maintenance work” on page 50.

- Lever the fan wheel down from the motor shaft with a suitable tool.
- For the installation of the new fan wheel, pay attention to the correct bearing of the tolerance ring in the hub groove.

- The fan wheel has to be pressed on as far as possible when it is installed. Only press here in the area of the hub.

11 Faults, causes and remedies

Have faults remedied by qualified personnel only! Observe the safety instructions in chapter 10 “Maintenance” on page 48.

- **If the malfunction cannot be rectified, consult a specialist technician or the nearest customer service or representative office.**

Fault displays

For faults, causes and remedies, see the “Fault/warning signal” flow diagram (see chapter 11.3 “Acknowledging errors” on page 59, Fig. 50 – Fig. 55) and the following tables. The first column of the table lists the code numbers displayed in the event of a fault.



NOTE:

If the cause of the fault no longer exists, some faults resolve themselves automatically.

Legend

The following types of errors can occur with differing priorities (1 = lowest priority; 6 = highest priority):

Error type	Explanation	Priority
A	Permanent error	6
B	Permanent error on the 6th occurrence	5
C	Warning, after 5 min, transition to an error permanent error on the 6th occurrence	4
D	Like error type A, but error type A has a higher priority than error type D	3
E	Emergency operation: warning with emergency operation speed and activated SSM	2
F	Warning	1

11.1 Mechanical faults

Fault	Cause	Remedy
Pump does not start or stops working	Cable terminal loose	Check all cable connections
	Fuses faulty	Check fuses; replace defective fuses
Pump is running at reduced output	Stop valve on pressure side throttled	Slowly open the stop valve
	Air in the suction line	Seal leaks at the flanges; bleed
Pump is making noise	Insufficient supply pressure	Increase supply pressure, observe minimum pressure at the suction port, check slide valve and filter on the suction side and clean if necessary
	Motor has bearing damage	Have the pump checked by Wilo customer service or a specialized service center and serviced if necessary

11.2 Error table

Classification	No.	Error	Cause	Remedy	Error type	
					HV	AC
-	0	No error				
System errors	E004	Undervoltage	Mains overloaded	Check electrical installation	C	A
	E005	Overvoltage	Mains voltage too high	Check electrical installation	C	A
	E006	2-phase operation	Missing phase	Check electrical installation	C	A
	E007	Warning! Generator operation (flow in flow direction)	The flow is driving the pump impeller; electrical current is being fed back to the mains	Check the setting; check system for proper operation Caution! Prolonged operation can cause damage to the module	F	F
	E009	Warning! Turbine operation (flow in flow direction)	The flow is driving the pump impeller; electrical current is being fed back to the mains	Check the setting; check system for proper operation Caution! Prolonged operation can cause damage to the module	F	F
Pump error	E010	Blocking	Shaft is mechanically blocked	If the blocking has not been removed after 10 seconds, the pump switches off. Check shaft for ease of movement. Request customer service	A	A
Motor errors	E020	Excess winding temperature	Motor overloaded	Allow motor to cool down Check settings Check/correct the duty point	B	A
			Motor ventilation limited	Provide unobstructed air access		
			Water temperature too high	Lower water temperature		
	E021	Motor overload	Duty point outside of duty chart	Check/correct the duty point	B	A
			Deposits in the pump	Request customer service		
	E023	Short circuit/ground leakage	Motor or module defective	Request customer service	A	A
	E025	Faulty contact	Module has no contact to motor	Request customer service	A	A
Winding interrupted		Motor defective	Request customer service			
E026	WSK or PTC interrupted	Motor defective	Request customer service	B	A	
Module errors	E030	Excess module temperature	Limited air supply to module heat sink	Provide unobstructed air access	B	A
	E031	Excess hybrid/power section temperature	Ambient temperature too high	Improve room ventilation	B	A
	E032	Intermediate circuit undervoltage	Voltage fluctuations in the mains	Check electrical installation	F	D
	E033	Intermediate circuit overvoltage	Voltage fluctuations in the mains	Check electrical installation	F	D
	E035	DP/MP: multiple instances of same identity	multiple instances of same identity	Reallocate master and/or slave (see chap. 9.2 on page 46)	E	E

Classification	No.	Error	Cause	Remedy	Error type	
					HV	AC
Communication error	E050	BMS communication time-out	Bus communication interrupted or timed out Cable break	Check cable connection to building automation	F	F
	E051	Impermissible DP/MP combination	Different pumps	Request customer service	F	F
	E052	DP/MP communications time-out	Cable MP communication defective	Check cable and cable connections	E	E
Electronics faults	E070	Internal communication error (SPI)	Internal electronics error	Request customer service	A	A
	E071	EEPROM error	Internal electronics error	Request customer service	A	A
	E072	Power section/frequency converter	Internal electronics error	Request customer service	A	A
	E076	Internal transformer defective	Internal electronics error	Request customer service	A	A
	E077	24 V operating voltage for sensor defective	Sensor defective or connected incorrectly	Check differential pressure sensor connection	A	A
	E096	Infobyte not set	Internal electronics error	Request customer service	A	A
	E097	Flexpump data record missing	Internal electronics error	Request customer service	A	A
	E098	Flexpump data record invalid	Internal electronics error	Request customer service	A	A
	E110	Motor synchronization error	Internal electronics error	Request customer service	B	A
	E111	Excess current	Internal electronics error	Request customer service	B	A
	E112	Excess rotation speed	Internal electronics error	Request customer service	B	A
System errors	E119	Turbine operation error (flow in flow direction; pump cannot start)	The flow is driving the pump impeller; electrical current is being fed back to the mains	Check the setting; check system for proper operation Caution! Prolonged operation can cause damage to the module	A	A

11.3 Acknowledging errors

General

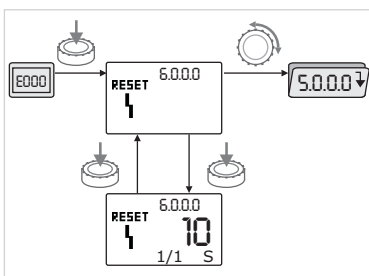

Fig. 50: Navigation in case of error



In the event of an error, the error page is displayed instead of the status page.

In this case, the following procedure can generally be used for navigation (Fig. 50):



- To change to menu mode, press the red button.

Menu number <6.0.0.0> flashes on the display.

By turning the red button, it is possible to navigate in the menu as usual.



- Press the red button.

Menu number <6.0.0.0> appears steady on the display.

On the units display, the current incidence (x) as well as the maximum incidence of the error (y) are displayed in the format "x/y".

Until the error can be acknowledged, pressing the red button again will cause a return to menu mode.



NOTE:
A 30-second time-out causes the display to revert to the status page or error page.



NOTE:
Every error number has its own error counter, which counts the incidence of the error within the last 24 hours and is reset after manual acknowledgment, 24-hour continuous "mains on" or a new "mains on".

11.3.1 Error type A or D

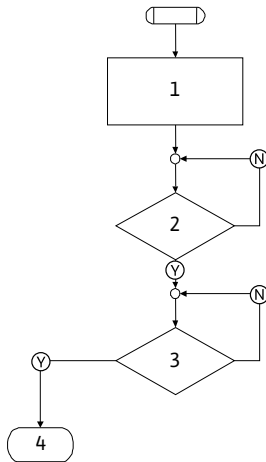

Fig. 51: Error type A, diagram

Error type A (Fig. 51):

Program step/query	Contents
1	<ul style="list-style-type: none"> • Error code is displayed • Motor off • Red LED on • SSM is activated • Error counter is incremented
2	> 1 minute?
3	Error acknowledged?
4	End; auto control resumes
Ⓨ	yes
Ⓝ	no

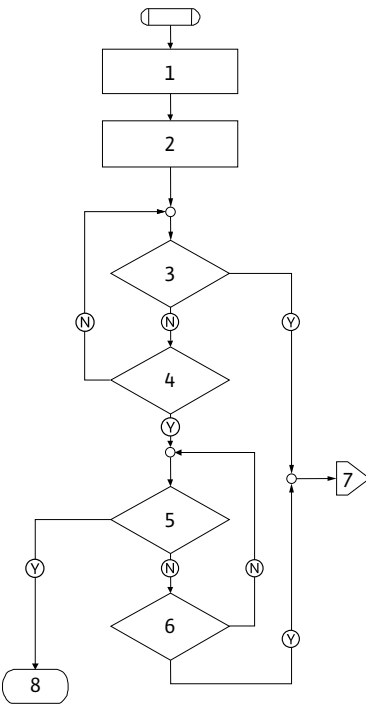

Fig. 52: Error type D, diagram

Error type D (Fig. 52):

Program step/query	Contents
1	<ul style="list-style-type: none"> • Error code is displayed • Motor off • Red LED on • SSM is activated
2	• Error counter is incremented
3	Is there a new type "A" fault?
4	> 1 minute?
5	Error acknowledged?
6	Is there a new type "A" fault?
7	Branching for error type "A"
8	End; auto control resumes
Ⓨ	yes
Ⓝ	no

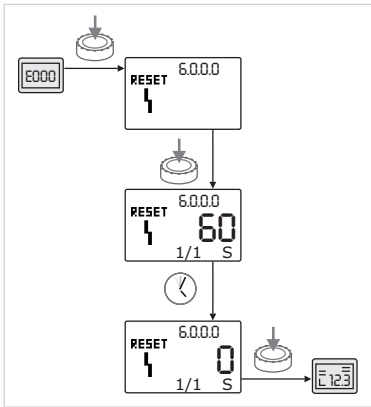





Fig. 53: Acknowledge error type A or D

If type A or D errors occur, proceed as follows to acknowledge (Fig. 53):

-  • To change to menu mode, press the red button.
Menu number <6.0.0.0> flashes on the display.
-  • Press the red button again.
Menu number <6.0.0.0> appears steady on the display.
The time remaining until the error can be acknowledged is displayed.
-  • Wait until the remaining time is up.
The time until manual acknowledgment is always 60 seconds for error types A and D.
-  • Press the red button again.
The error is acknowledged, and the status page is displayed.

11.3.2 Error type B

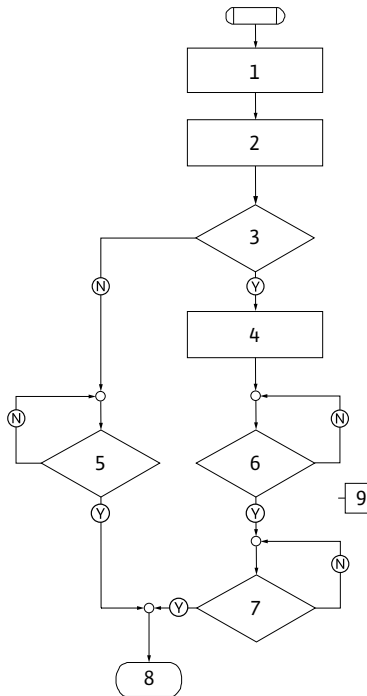



Fig. 54: Error type B, diagram

Error type B (Fig. 54):

Program step/query	Contents
1	• Error code is displayed • Motor off • Red LED on
2	• Error counter is incremented
3	Error counter > 5?
4	• SSM is activated
5	> 5 minutes?
6	> 5 minutes?
7	Error acknowledged?
8	End; auto control resumes
9	Error E021 > 1 minute
(Y)	yes
(N)	no

If type B errors occur, proceed as follows to acknowledge:

-  • To change to menu mode, press the red button.
Menu number <6.0.0.0> flashes on the display.
-  • Press the red button again.
Menu number <6.0.0.0> appears steady on the display.
On the units display, the current incidence (x) as well as the maximum incidence of the error (y) are displayed in the format “x/y”.

Incidence X < Y

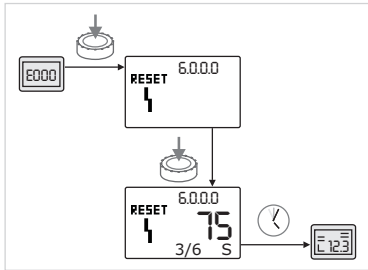

Fig. 55: Acknowledge error type B (X < Y)



- If the current incidence of the error is less than the maximum incidence (Fig. 55):
 - Wait for auto reset time.
 - On the value display, the remaining time until auto reset of the error is displayed in seconds.
 - After the auto reset time has run out, the error will be automatically acknowledged and the status page will be displayed.



NOTE:
The auto reset time can be set on menu number <5.6.3.0> (time input 10 to 300 s)

Incidence X = Y

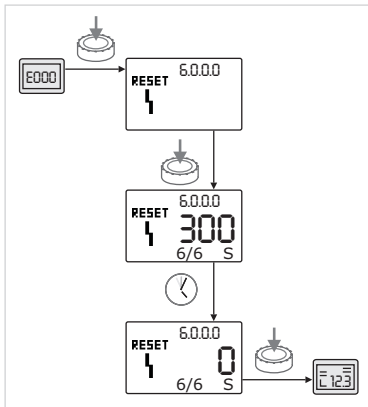

Fig. 56: Acknowledge error type B (X=Y)



- If the current incidence of the error is the same as maximum incidence (Fig. 56):
 - Wait until the remaining time is up.
 - The time until manual acknowledgment is always 300 seconds.
 - On the value display, the remaining time until manual acknowledgment of the error is displayed in seconds.



- Press the red button again.
- The error is acknowledged, and the status page is displayed.

11.3.3 Error type C

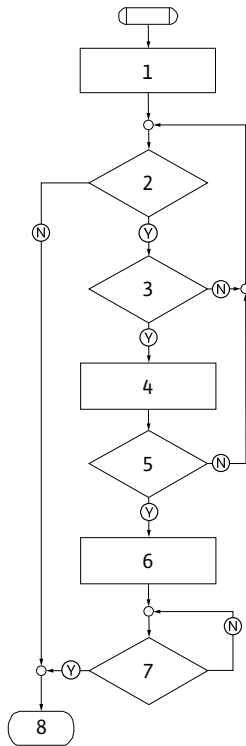

Fig. 57: Error type C, diagram

Error type C (Fig. 57):

Program step/query	Contents
1	• Error code is displayed • Motor off • Red LED on
2	Error criterion fulfilled?
3	> 5 minutes?
4	• Error counter is incremented
5	Error counter > 5?
6	• SSM is activated
7	Error acknowledged?
8	End; auto control resumes
Ⓨ	yes
Ⓝ	no

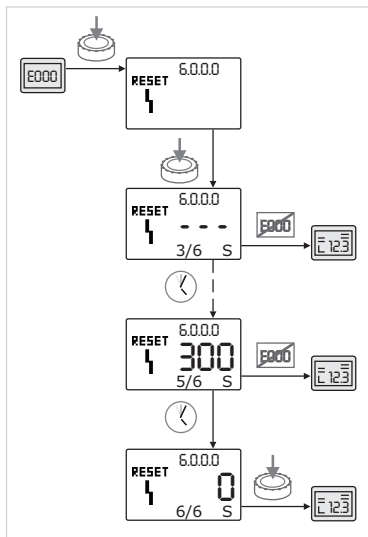

Fig. 58: Acknowledge error type C

If type C errors occur, proceed as follows to acknowledge (Fig. 58):



- To change to menu mode, press the red button.

Menu number <6.0.0.0> flashes on the display.



- Press the red button again.

Menu number <6.0.0.0> appears steady on the display.

On the value display, “- - -” appears.

On the units display, the current incidence (x) as well as the maximum incidence of the error (y) are displayed in the format “x/y”.

After 300 seconds, the current incidence will be counted up by one.



NOTE:

The error will be acknowledged automatically if the cause of the error is eliminated.



- Wait until the remaining time is up.

If the current incident (x) is the same as the maximum incidence of the error (y), this error can be acknowledged manually.



- Press the red button again.

The error is acknowledged, and the status page is displayed.

11.3.4 Error type E or F

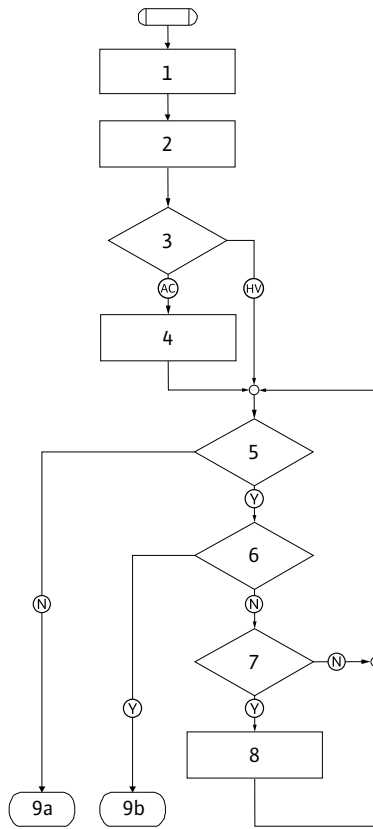

Fig. 59: Error type E, diagram

Error type E (Fig. 59):

Program step/query	Contents
1	• Error code is displayed • Pump goes into emergency operation
2	• Error counter is incremented
3	Error matrix AC or HV?
4	• SSM is activated
5	Error criterion fulfilled?
6	Error acknowledged?
7	Error matrix HV and > 30 minutes?
8	• SSM is activated
9a	End; auto control (double pump) resumes
9b	End; auto control (single pump) resumes
(Y)	yes
(N)	no

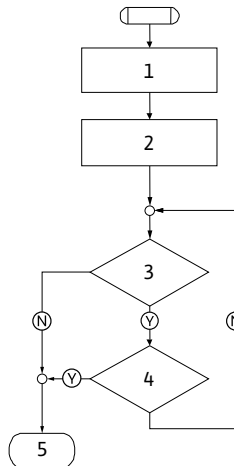

Fig. 60: Error type F, diagram

Error type F (Fig. 60):

Program step/query	Contents
1	• Error code is displayed
2	• Error counter is incremented
3	Error criterion fulfilled?
4	Error acknowledged?
5	End; auto control resumes
(Y)	yes
(N)	no



Fig. 61: Acknowledge error type E or F



If type E or F errors occur, proceed as follows to acknowledge (Fig 61):

- To change to menu mode, press the red button.
Menu number <6.0.0.0> flashes on the display.



- Press the red button again.

The error is acknowledged, and the status page is displayed.



NOTE:

The error will be acknowledged automatically if the cause of the error is eliminated.

12 Spare parts

Spare parts may be ordered via a local specialist retailer and/or WILO-customer service.

To avoid queries and incorrect orders, all data on the name plate should be submitted for each order (pump name plate Fig. 9 Item 1).



CAUTION! Danger of property damage!

Trouble-free pump operation can only be guaranteed when original spare parts are used.

- **Only use original Wilo spare parts.**
- **Information to be provided when ordering spare part:**
 - Spare part number
 - Name/description of the spare part
 - All data of the pump name plate



NOTE:

List of genuine spare parts: see Wilo spare parts documentation (www.wilo.com). The item numbers of the exploded drawings (Fig. 7) are only for orientation and listing of the main components (table 1). Do not use these item numbers when ordering spare parts.

13 Disposal

Proper disposal and recycling of this product prevents damage to the environment and risks to personal health.

1. Use public or private disposal organizations when disposing of all or part of the product.
2. For more information on proper disposal, please contact your municipal government or waste disposal office or the supplier from whom you obtained the product.

Subject to change without prior notice!